



Download
Manual



🔍 Growatt New Energy

Growatt USA, Inc
9227 Reseda Blvd, #435 Northridge, CA 91324, USA.

T 1(866) 686-0298
E usaservice@ginverter.com
W www.growatt-america.com

GR-UM-251-A-00



MIN 3K-11.4K TL-XH-US & Commissioning Guide

List

1 Power on the system

- 1.1 Energy Management System Introduction
- 1.2 Check System Installation & Power On

2 ShineTools APP Setup

- 2.1 APP Download
- 2.2 APP Introduction
- 2.3 Connecting to Local Wi-Fi Network

3 Grid Code Mapping Table

4 Wi-Fi Network Configuration

5 Energy Management System

- 5.1 Management System Mode Introduction
- 5.2 Energy Management System setting

6 Battery Life Maintenance

7 Troubleshooting Commissioning Error Code

8 ShineServer Operation

- 8.1 Register an Account
- 8.2 Create a power plant
- 8.3 Add Data Logger to power plant

9 Shinephone Introduction

- 9.1 APP Download
- 9.2 APP Introduction

1 Power on the system

1.1 Energy Management System Introduction

MIN 3K-11.4KTL-XH-US energy storage system diagram is shown in the figure below:

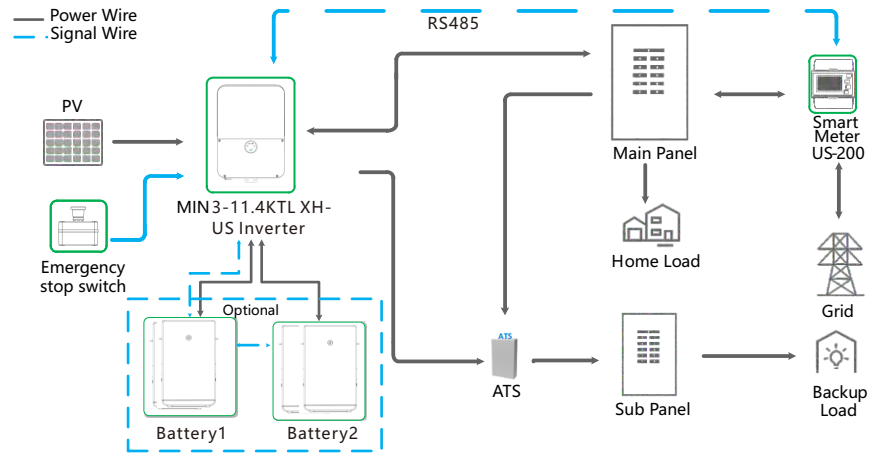

Fig 1.1

The system wiring diagram is as follows:

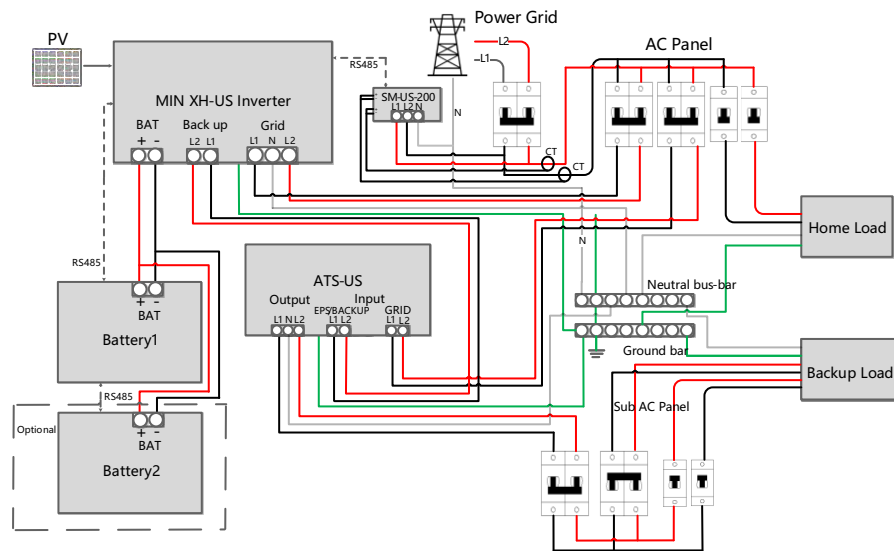

Fig 1.2

MIN 3K-11.4KTL-XH-US AC Couple system diagram is shown in the figure below:

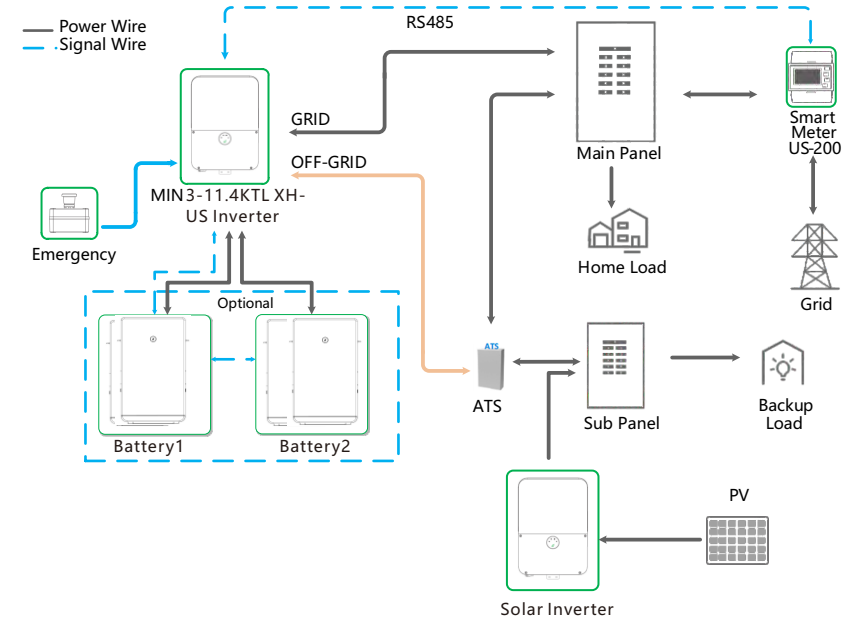

Fig 1.3

The AC Couple system wiring diagram is as follows:

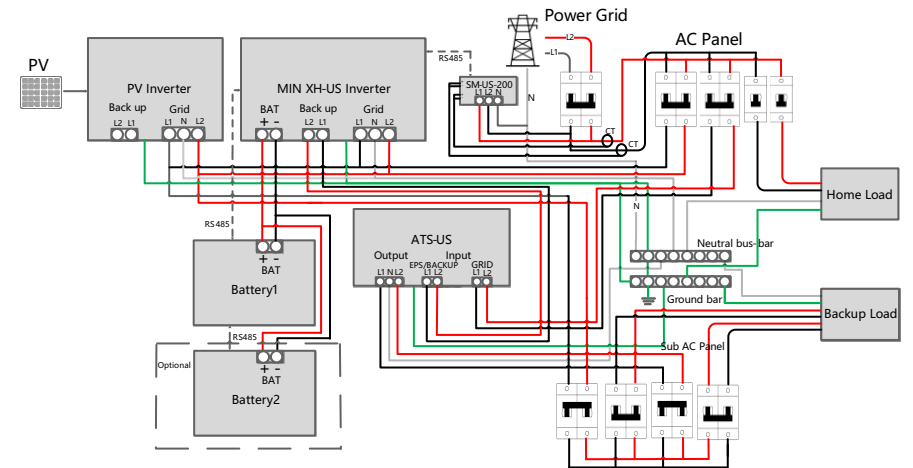

Fig 1.4

1.1.1 System Configuration Contains

Energy Storage System / Off-Grid System.

- MIN 3-11.4KTL-XH-US inverter.
- ARO battery(s) or LG battery(s).
- ATS.

➤ Electric meter SM-US-200 .

Inverter Grid-Connected System.

- MIN 3-11.4K TL-XH-US inverter.
- Electric meter SM-US-200 (Optional).

Product	Model	Function	Note
Inverter	MIN 3K-11.4KTL-XH-US	Energy conversion	
ARO Battery	ARO 6.6-19.8H-C1-US	Energy storage	UP TO 4
LG Battery	RESU10H/16H Prime	Energy storage	UP TO 2
ATS	ATS 11.4KT-US	EPS switching	
Smart meter	SM-US-200	Energy management	
Button	RSD Button	Rapid shutdown	Accessory (included in the package)

1.2 Check System Installation & Power On

All components were installed according to the installation guides, please check the following highlighted installation locations:

Power on the system according to the MIN 3000-11400TL-XH-US Quick Guide which is included in the inverter package/box.

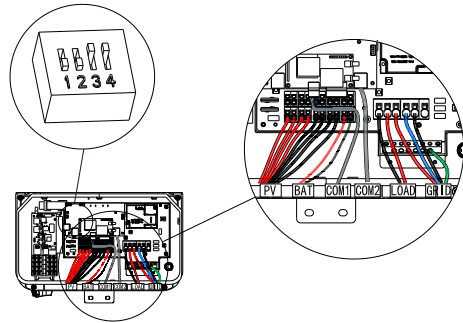

Fig 1.5 Inverter Box Wiring Diagram

- ARO Battery Wiring Diagram please refer to ARO 6.6-19.8H-C1-US Quick Guide
- LG Battery Wiring Diagram please refer to LG RESU10H/16H Prime Quick Guide
- ATS-11.4K Wiring Diagram please refer to ATS-US Series Quick Guide

1.2.1 Installation and Wiring of Electric Meter SM-US-200

a) Meter Mounting

- The meter should be mounted in a Power Distribution Box.
- Mount the meter on a 35mm DIN rail.

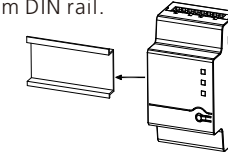

Fig 1.6

b) CT Installation

Install the two CTs with the Arrow pointing to the LOAD.

- Make sure the CT of L1 matched L1 input of the Service Panel that also match the L1 to the inverter.
- Make sure the CT of L2 matched L2 input of the Service Panel that also match the L1 to the inverter.

c) Meter Wiring

- When connecting the meter to the inverter, refer to the connection diagram below.

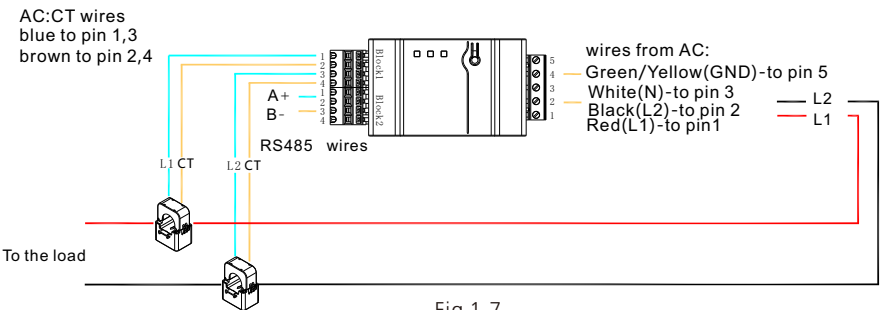

Fig 1.7

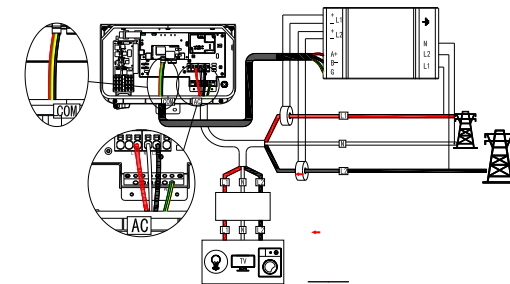

Fig 1.8

- RS485 cables Ground, B- & A+ was installed from the left to right when facing the meter. Please refer to the silk screen on the meter.

2 ShineTools APP Setup

2.1 APP Download

There are two ways to download the ShineTools APP:

- a) Scan the QR code
 - Scanning the QR code through phone camera for downloading the APP.



Fig2.1 ShineTools App QR code

- b) APP Store
 - Search for ShineTools App from app stores (App or Play Store).
 - The ShineTools App icon is displayed the same as the Figure 4.
 - Download and install the App by following the installation instructions.



Fig2.2 ShineTools App QR code



2.2 APP Introduction

ShineTools is used to connect the inverter with built-in WIFI at close range. We can view the inverter system information and system function settings with it.

2.3 Connecting to Local Wi-Fi Network

The steps for using APP are as follows:

Setup local Wi-Fi to communicate with the inverter		
1.Login interface	2.Enter the default password and log in	3. Tap in Direct WiFi
	<p>The default password is oss+ day. Ex: if today's date is Dec 29, 2020, the default password would be oss20201229, You can change the password according to the prompts below.</p>	
4. Tap in Go to set	5. Open the Wi-Fi settings on the mobile phone	6. The Wi-Fi name is the Serial Number on the label
		<p>The Wi-Fi password is 12345678</p>

<p>7. Tap in Next</p> 	<p>8. Tap in Auto refresh</p> 	<p>Now this APP has been connected to the built-in WIFI of the inverter.</p>
--	---	--

Note:
 When no data was present, the communication connection is unsuccessful and you will need to reconnect the build-in WIFI of the inverter by turning off Wifi setting in the phone and turn on again OR power cycle the system.
 Also, keep the mobile phone within 3 meters of the inverter to ensure stable connection between phone and inverter.

2.4 Local Commissioning Main Interface Introduction

The main interface of local commissioning consists of three parts:

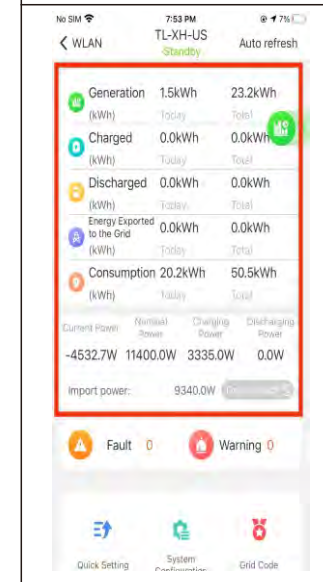
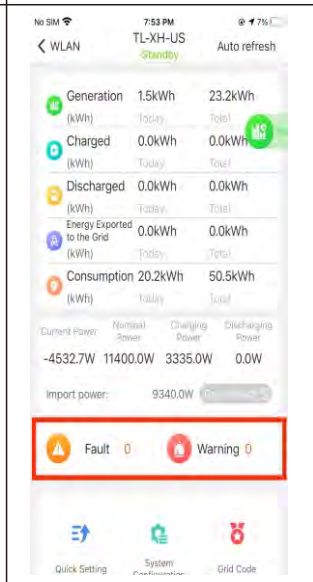
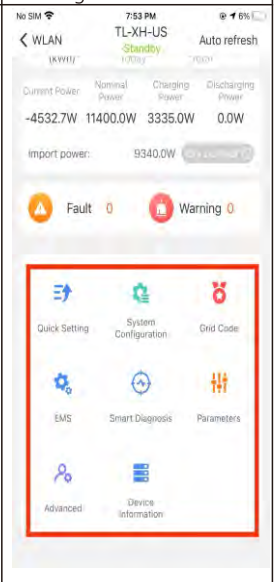
Power generation information	Fault warning message	Internal information viewing and parameter setting															
 <table border="1"> <thead> <tr> <th>Generation (kWh)</th> <th>Charged (kWh)</th> <th>Discharged (kWh)</th> <th>Energy Exported to the Grid (kWh)</th> <th>Consumption (kWh)</th> </tr> </thead> <tbody> <tr> <td>1.5kWh</td> <td>0.0kWh</td> <td>0.0kWh</td> <td>0.0kWh</td> <td>20.2kWh</td> </tr> <tr> <td>23.2kWh</td> <td>0.0kWh</td> <td>0.0kWh</td> <td>0.0kWh</td> <td>50.5kWh</td> </tr> </tbody> </table>	Generation (kWh)	Charged (kWh)	Discharged (kWh)	Energy Exported to the Grid (kWh)	Consumption (kWh)	1.5kWh	0.0kWh	0.0kWh	0.0kWh	20.2kWh	23.2kWh	0.0kWh	0.0kWh	0.0kWh	50.5kWh	 <p>Fault 0 Warning 0</p>	 <ul style="list-style-type: none"> Quick Setting System Configuration Grid Code EMS Smart Diagnosis Parameters Advanced Device Information
Generation (kWh)	Charged (kWh)	Discharged (kWh)	Energy Exported to the Grid (kWh)	Consumption (kWh)													
1.5kWh	0.0kWh	0.0kWh	0.0kWh	20.2kWh													
23.2kWh	0.0kWh	0.0kWh	0.0kWh	50.5kWh													



3 Grid Code Mapping Table

The factory Default grid mode of the inverter is IEEE1547-240, which can adapt to the most power grids. The different grid code can be changed according to local regulation in the network configuration interface from Quick Setting in ShineTools App.

No.	Grid Code	Description	No.	Grid Code	Description
1	HECO-208	US Hawaii low-voltage power grid	2	HECO-240	US Hawaii low-voltage power grid
3	IEEE1547-208	US low-voltage power grid	4	IEEE1547-240	US low-voltage power grid
5	PRC-East-208	Eastern US low-voltage power grid	6	PRC-East-240	Eastern US low-voltage power grid
7	PRC-Quebec-208	Canada Quebec low-voltage power grid	8	PRC-Quebec-240	Canada Quebec low-voltage power grid
9	RULE21-208	US California low-voltage power grid	10	RULE21-240	US California low-voltage power grid

Wi-Fi Network Configuration 4

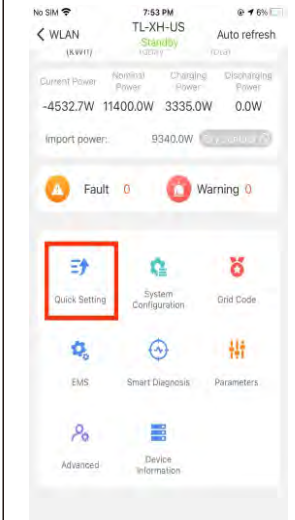
First time install the inverter, the inverter needs to be configured to connect to the home Wi-Fi to ensure the remote monitoring.

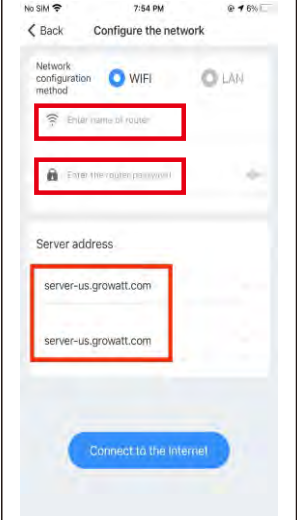
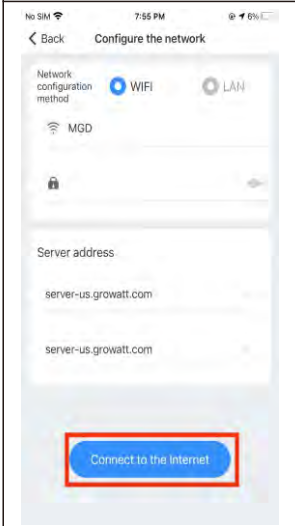
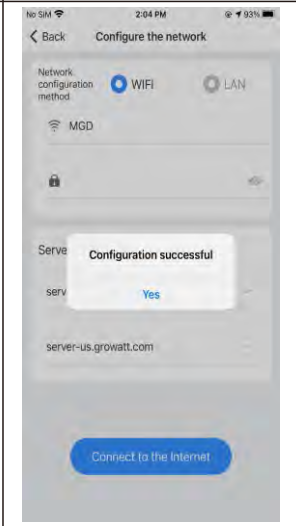
<p>1. Tap in Quick Setting icon</p> 	<p>2. Choose Network configuration</p> 	<p>3. Enter network information</p> 
<p>4. Tap in Connect to the internet icon</p> 	<p>5. Prompt message for successful configuration</p> 	
<p>Note: If the network configuration has failed, please carefully check the Wi-Fi name, password and antenna installation connection, and then try again. Notice: The inverter does not support 5GHz WiFi network.</p>		

5 Energy Management System

Notice: First time install the energy storage system, charge the battery for at least 1 hours or up to 60% SOC before powering off the system. This action will keep up the battery power to avoid running out while waiting for PTO.

There are two ways to charge the battery.

- The first is to connect the PV array to the PV of the inverter and turn off the AC output breaker of the inverter.
- The second method is to connect the AC output of the inverter to the grid without any PV input, set the EMS mode of the system to **TOU Battery Charging (5.2.3)**, and turn on the AC charging function (5.2.2).

5.1 Management System Mode Introduction

The MIN 3K-11.4K TL-XH-US system provides four energy storage modes to choose from.

Storage Mode	Description
TOU Battery Charging	Charge battery from PV production and grid power (if needed) until it is full. Only then use PV production for self-consumption and grid export
TOU Battery Discharging	If PV Production < Inverter Maximum Production (nameplate or limited power), discharge battery for self-consumption and grid export until the inverter reaches its power limit or max battery discharge power.

Maximum self-consumption	Use PV production for self-consumption, then charge/discharge battery as needed to maximize self-consumption
Maximum self-consumption	
Export Limit	The power output from the system to the grid is limited at the set value
Export Limit	





5.2 Energy Management System setting

For the photovoltaic energy storage system, several functions of the system need to set after the first installation and power-up.

5.2.1 Power Sensor Setting

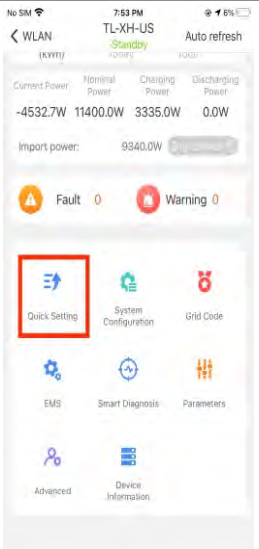

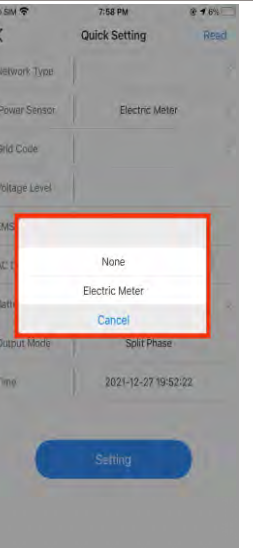
If an electric meter is installed in the system, please set. Factory Default is Disabled.

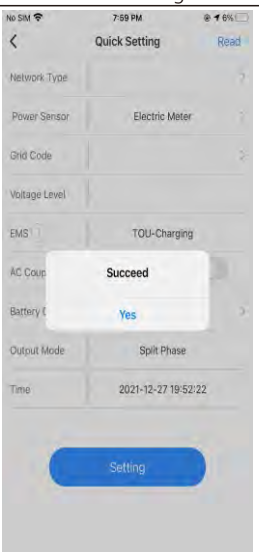
**Note: Power Sensor: iOS = Electric meter
Android = Meter**

<p>1. Tap in Quick Setting icon</p> 	<p>2. Choose Network configuration</p> 	<p>3. Enter network information</p> 
<p>4. Tap in setting</p> 	<p>5. Prompt message for successful setting</p> 	

5.2.2 AC Charging Setting

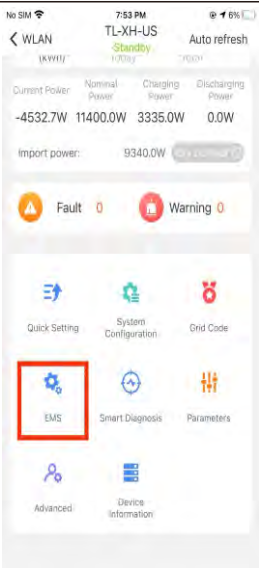
The AC charging is used to set whether to allow charging the battery from the Grid.
Factory Default is Disabled.

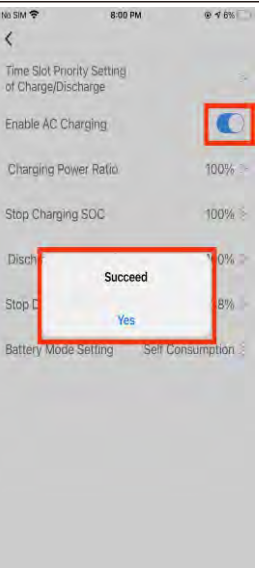
<p>1. Tap in Charge and Discharge Management</p> 	<p>2. Find Enable AC Charging</p> 	<p>3. Tap in ON/OFF button.</p> 
--	---	---

5.2.3 Battery type Setting

The Battery type setting is to choose ARO Battery or LG Battery
Factory Default is ARO Battery.

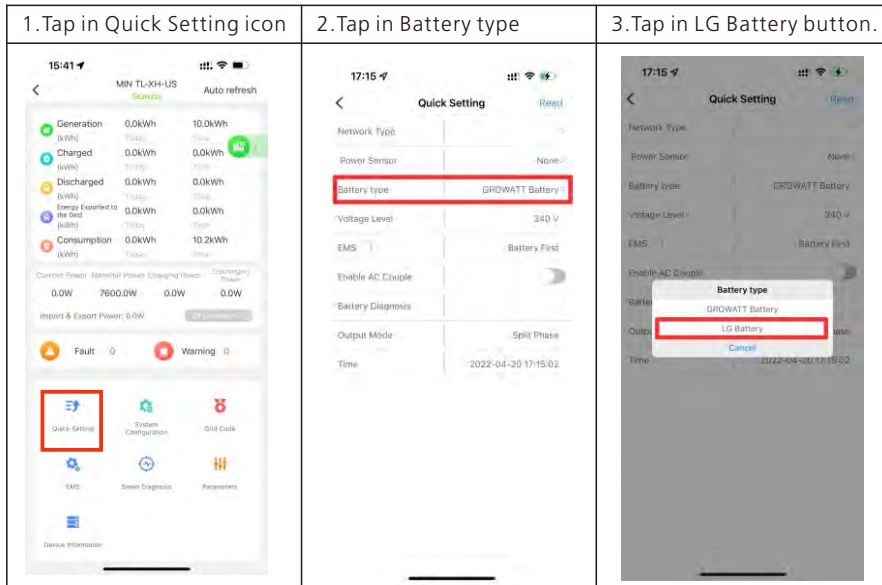

5.2.4 AC Couple Setting

The AC Couple setting is what the AC COUPLE system needs to set
Factory Default is Disabled.

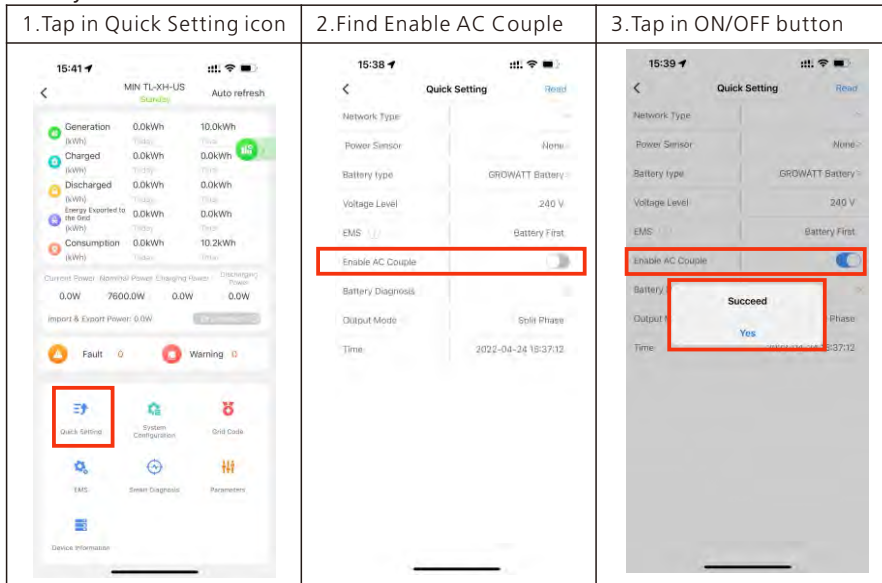

5.2.5 EMS Mode Setting:

If an ARO battery is installed in the system, you need to set the energy storage mode.

Factory Default is Maximum Self-Consumption.

Example: If the energy storage system is to be used as backup and only use the battery when the grid is powered off, set the battery charging and discharging time period to 24 hours for TOU Battery Charging.

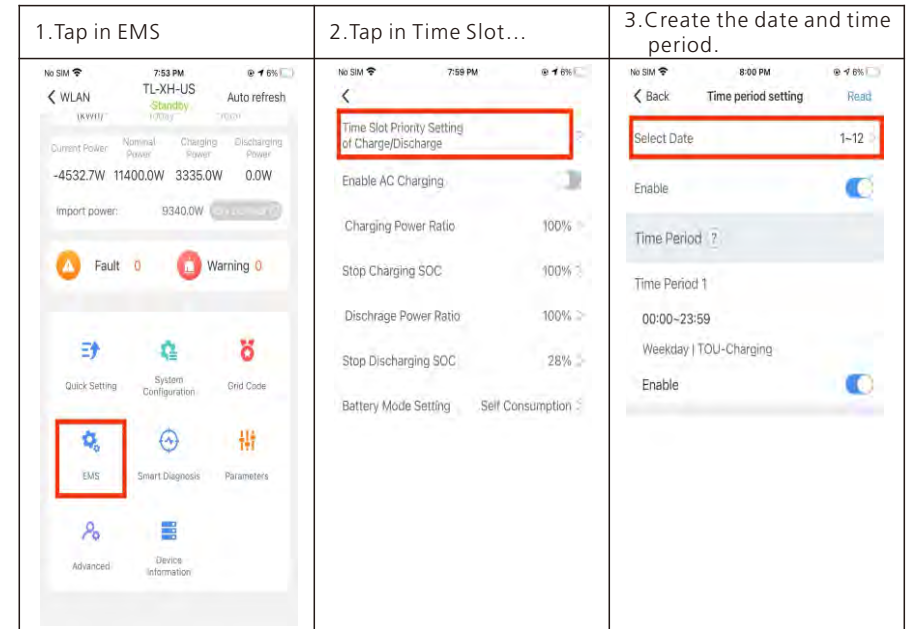

Battery Life Maintenance 6 (Important)

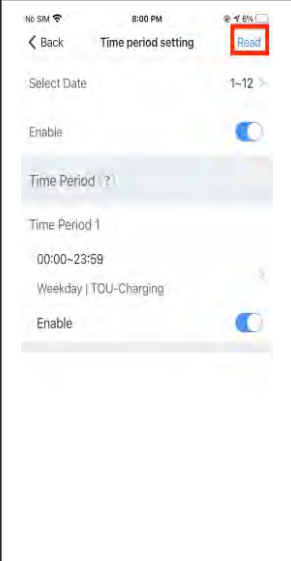
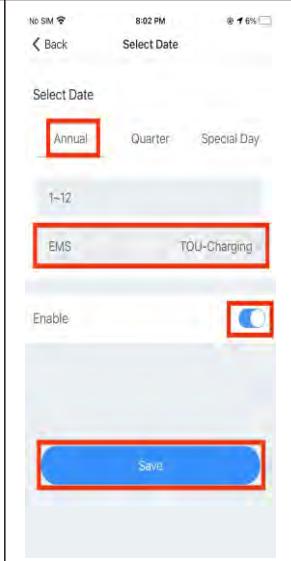
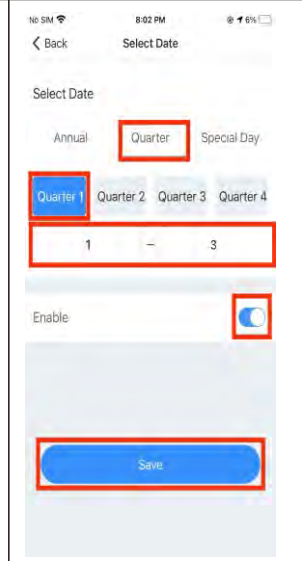
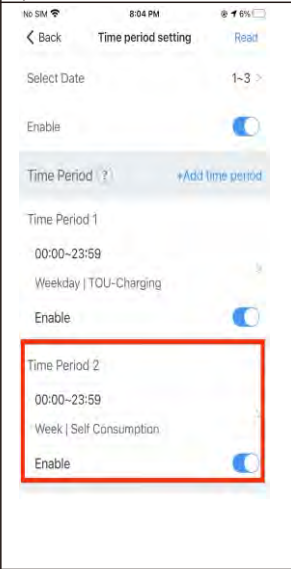
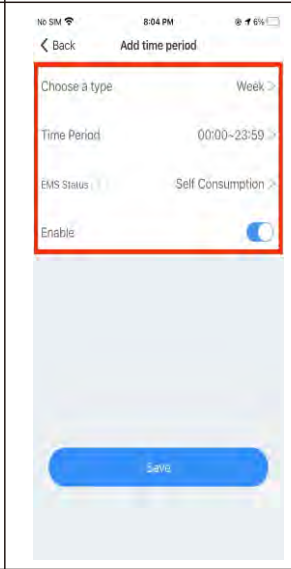
For Backup ONLY scenarios , it's done on No. 5		4. Select the Quarter to be set, Four quarters can be set
4. Select the TIME to be set	5. Select the YEAR to be set	
You only need to select the season or year to set.		
		
5. Increase time period, Maximum support 9 time periods	6. Set the mode within the time period	7. If you need to set more quarter or time periods, you need
		to operate step 4, 5, 6 multiple times You can also set the energy storage mode for special days if necessary.

- a) TUnplug Battery power, Battery Communication cables and turn OFF battery modules power (Check battery quick installation guide for the detail) . if the following conditions were met:
 - The installation is not completed.
 - No PV and AC power can charge the battery.
- b) Charge the battery SOC above 60% or higher after installation is complete and pending for AHJ/city review and approval.

7 Commissioning Error Code Troubleshooting

Enter the local commissioning home page, and view the fault and alarm information on the main interface if there are exist after installation. The fault and alarm code on the ShineServer Page will be the same in the APP. If you find a fault or alarm, please click it, and then you will be redirected to the interface of fault explanation and handling tips.

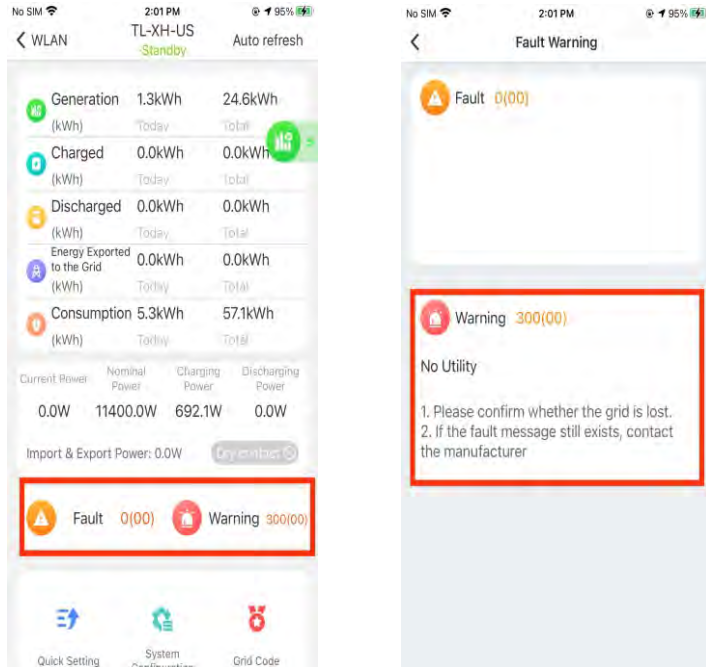

1. Common Fault and warning Codes

Fault code	Fault name	Possible cause	suggestion
Error 200	AFCI Fault	There is a problem on the wiring connection	1.After shutdown, check the panel terminal. 2.Decrease AFCI sensitivity and restart. 3.If error message still exists, contact manufacturer.
Error 201	Residual current High	PV panel insulation problem	1.Restart inverter. (Related to Grounding fault?) 2.If error message still exists, contact manufacturer.

Error 202	PV Voltage High	Too many PV panels connected in series	1.Immediately disconnect the DC switch and check the PV voltage. 2.If the fault code still exists after the normal voltage is restored, contact manufacturer.
Error 203	PV Isolation Low	PV panel insulation problem	1. Check PV panel and wiring.
Error 204	PV Reversed	PV positive and negative are reversed	1.After shutdown, Check the inverter terminal. 2. Restart inverter. 3.If error message still exists, contact manufacturer.
Error 300	AC overvoltage	Grid voltage overvoltage	1.Check grid voltage. 2. If the error message still exists despite the grid voltage being within the spec range, contact manufacturer.
Error 301	AC reversed	AC wiring error	1.Check AC terminals. 2.If error message still exists, contact manufacturer.
Error 302	No AC Connection	No AC Connection	1.After shutdown, Check AC wiring. 2. If error message still exists, contact manufacturer.
Error 303	NE abnormal	N or PE wring error	1.Check PE wiring. 2.Check N wiring.
Error 304	AC F Outrange	Abnormal grid frequency	1. Restart inverter. 2. If error message still exists, contact manufacturer.
Warning 217	BDC Abnormal	ARO battery error	1.Check ARO battery terminals 2.Check the connection between the inverter and the ARO battery.
Warning 218	BDC Bus Disconnect	Inverter and BDC wiring failure	1. Check the wire connection between the inverter and the ARO battery. 2.If error message still exists, contact manufacturer.

8 ShineServer Operation

ShineServer is the online monitoring platform that allows remote access through the ShinePhone App or any web browser. However, the premise is that the Wi-Fi network has been configured.

Account and plant information will be the same in both the web browser version and on the ShinePhone App.

8.1 Register an Account

- a) Log in to our monitoring website <http://server-us.growatt.com> and click Register an Account.

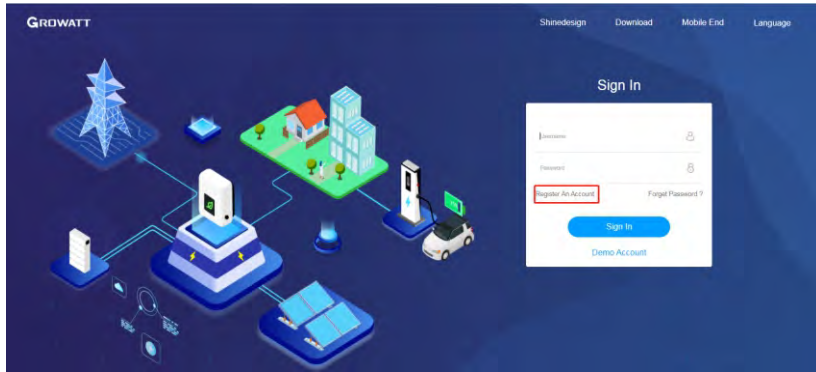

- b) Fill in the appropriate information on the registration interface and log into the account after the registration is completed.

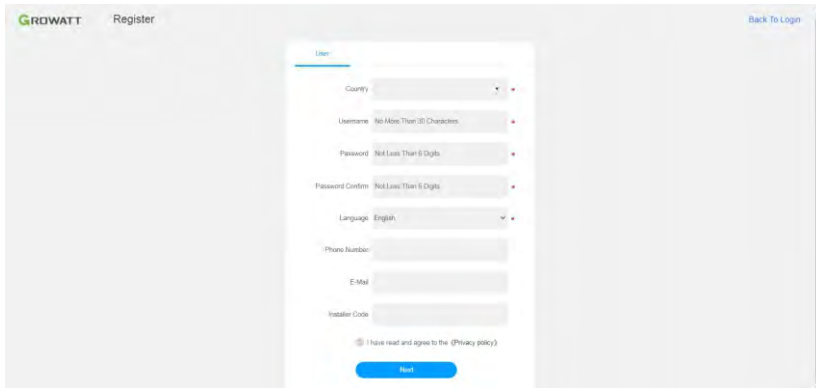

8.2 Create a power plant

- a) When you log into your account for the first time, you will be prompted to register a power plant.
- b) Click Add Plant on the upper right hand corner to create a power plant. A single account can contain multiple power plants.

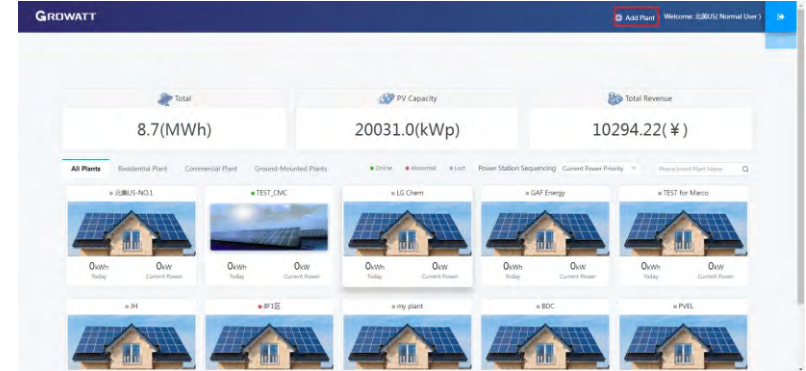

- c) Fill in the appropriate power plant information in order to complete the power plant creation.

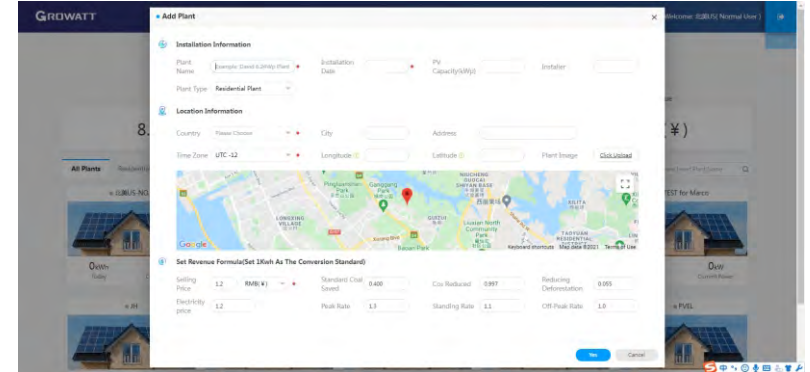

8.3 Add Data Logger to power plant

- a) Click on the power plant just created, enter the power plant page, and then add a data logger. The SN number of the collector is on the barcode on the side of the inverter, starting with VC. A power plant can contain multiple data loggers.

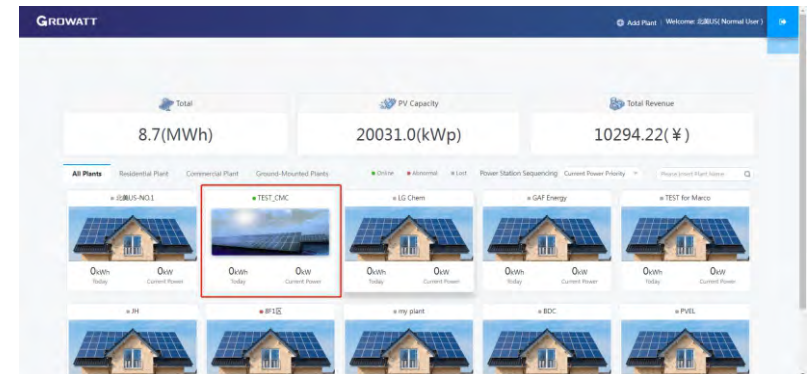

Shinephone Introduction 9

9.1 APP Download

There are two ways to download the ShinePhone APP:
c) Scan the QR code



Fig 9.1 ShinePhone downloading QR code

b) When you have completed these steps, you will be able to view the inverter system remotely through the ShinePhone APP and through any browser.

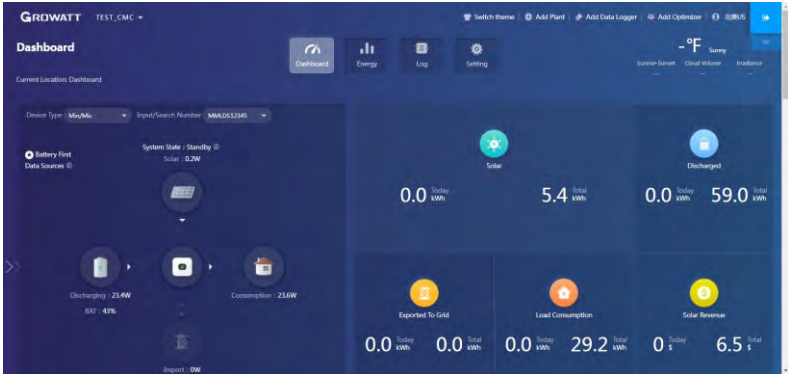

Scanning the QR code through WeChat or IOS's Camera, then download the APP.
d) APP Store
Search for ShinePhone from app stores, download the installation package, and install the ShinePhone app by following the instructions. the ShinePhone icon is displayed on the home screen.

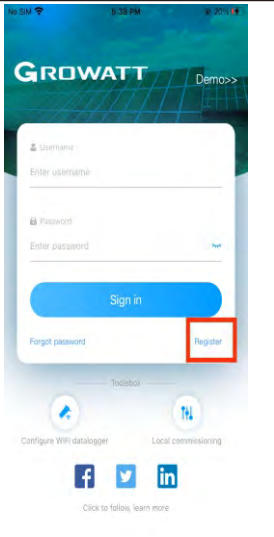
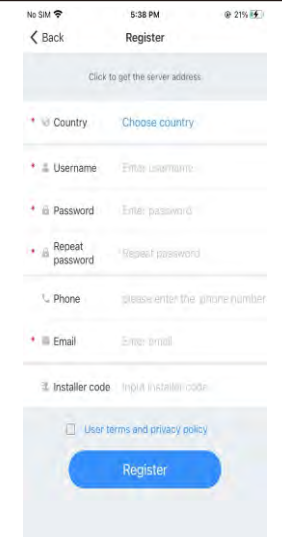
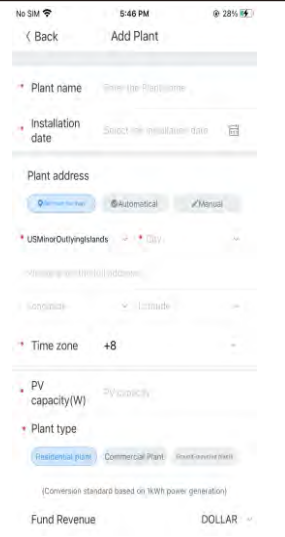

Fig 9.2 Icon of APP



9.2 APP Introduction

Shinephone can remotely monitor the inverter system information, which has the same function as shineserver, and the two information are shared. We can also register and create power stations through the shinephone app.

Setup local Wi-Fi to communicate with the inverter

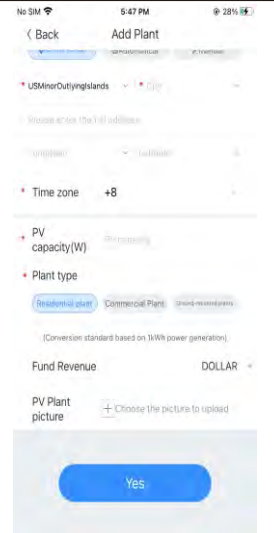
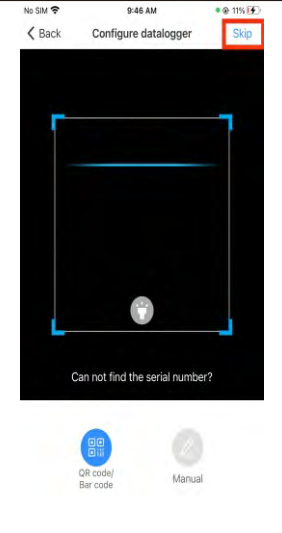
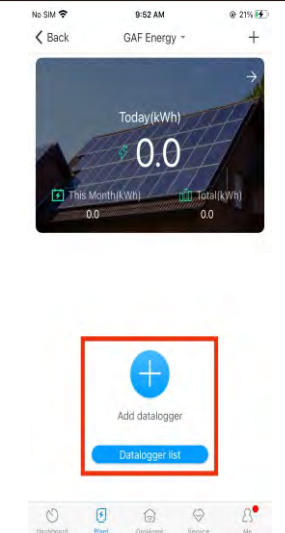
<p>1. Tap in Register</p>	<p>2. Fill the register info, Notice: For Installer code: ask for your installer, once you fill your installer code, your PV system would be authorized and monitored by your installer.</p>	<p>3. Fill the plant info</p>
		

<p>4. Continue fill the plant info</p>	<p>5. Tap in skip</p>	<p>6. Add collector</p>
		

<p>7. The Plant page display the list of plants under the plant account</p>	<p>8. tap in "+" to add the Plant.</p>	
		

Growatt USA, Inc
 9227 Reseda Blvd, #435 Northridge, CA 91324, USA.
 T 1(866) 686-0298
 E usaservice@ginverter.com
 W www.growatt-america.com