

1. Overview

1.1 Microinverter Overview

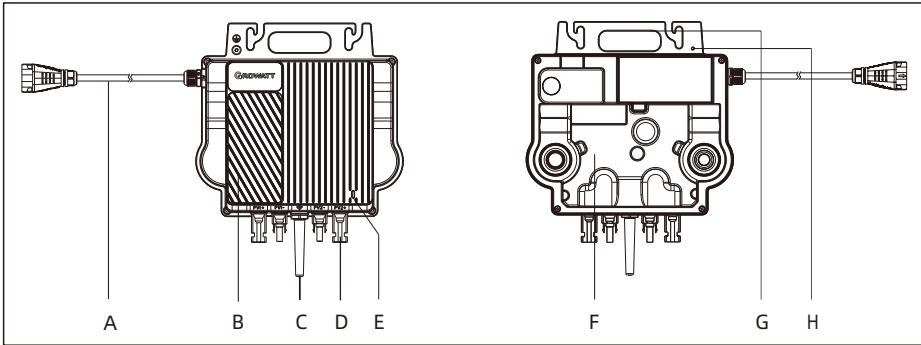

Position	Description
A	AC drop cable
B	Heat sink
C	Antenna
D	PV terminal
E	LED
F	Back plate
G	Handle
H	Grounding hole

⚠ Note:

1. This document is intended for use as a quick installation guide. For details, please refer to the Installation and Operation Manual.
2. Growatt shall not be liable for any damage caused by improper operations.

1.2 System Overview

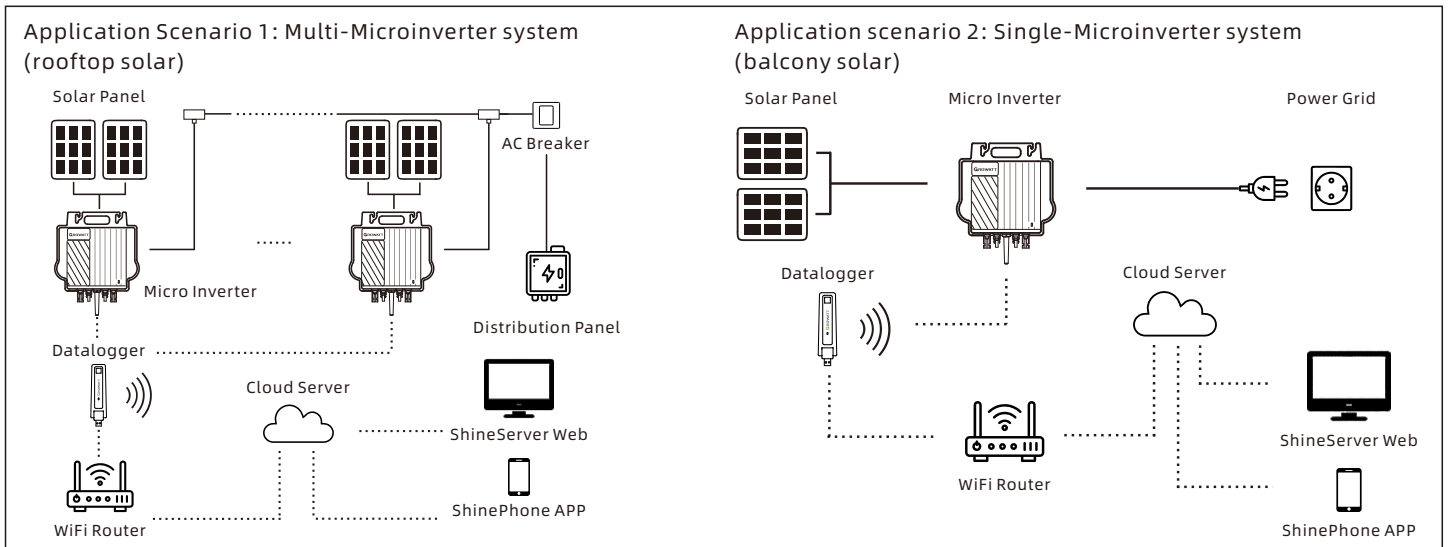

⚠ Note:

1. Up to five microinverters can be connected to the ShineWeLink.
2. Position the ShineWeLink next to the router, but maintain a minimum distance of 0.5m to avoid distortion resulting from the excessively strong signal.
3. Do not place the inverter, the router and the ShineWeLink on the same PV vertical line to avoid affecting the signal strength.

1.3 Accessories

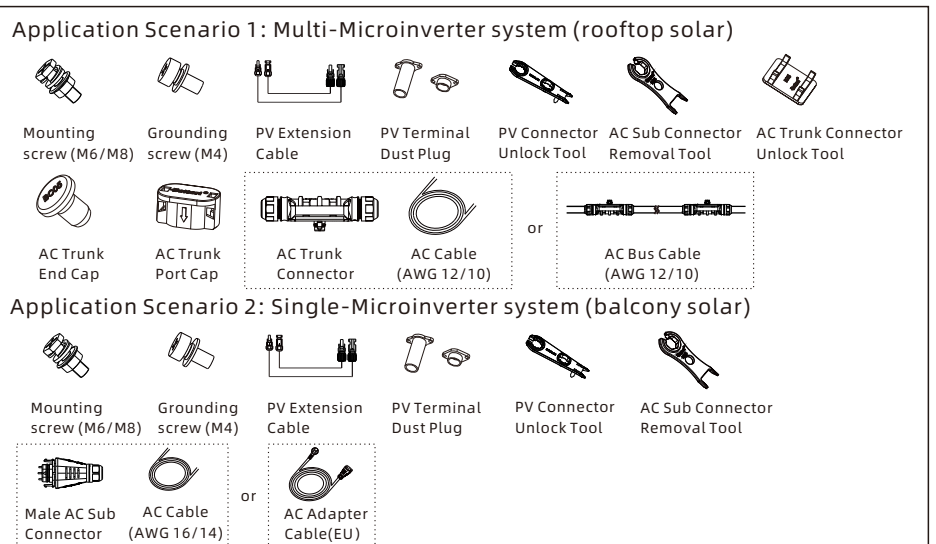
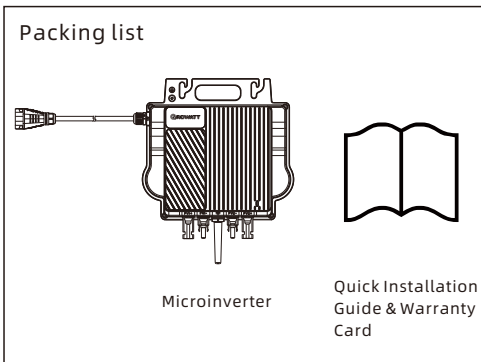

⚠ Note:

Please select the appropriate accessories and tools based on the on-site conditions.

2. Installation

Step 1 Install the NEO Microinverter

- Mount the NEO Microinverter to the rail using the mounting screws recommended by your module racking vendor.
- Maintain a minimum of 20 mm clearance between the roof and the back plate of the Microinverter to ensure ventilation and heat dissipation. Do not install the Microinverter at the gap between the PV modules.

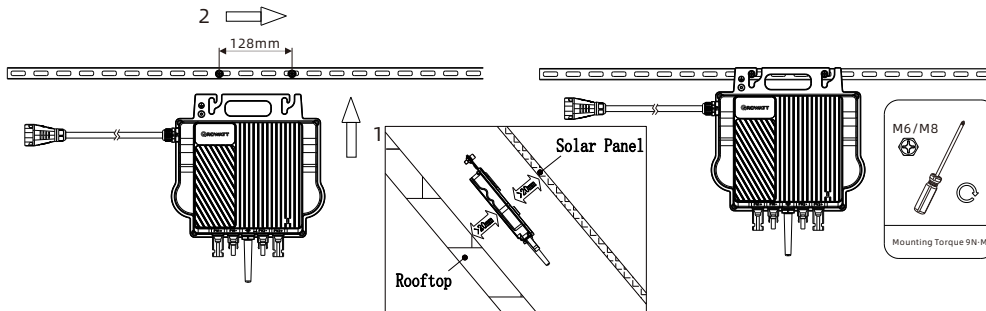

Step 2 Ground the system

- The AC drop cable has an embedded earth wire, which might be sufficient to ensure proper grounding.
- In area with special grounding requirements, external grounding may be needed by grounding the screw hole on the handle.

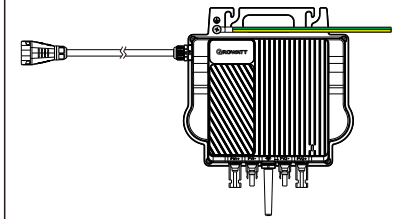

Step 3 Electrical Installation

Application Scenario 1: Multi-Microinverter system (rooftop solar)

1. AC connection

Method 1: Connect the Microinverter to the grid with the AC bus cable. (You can skip Steps a and b);

Method 2: Assemble the AC trunk connector and the AC cable to create the AC bus cable, then connect the Microinverter to the grid with the assembled cable.

- Prepare the AC trunk connector. Disassemble the connector as the figure shows.

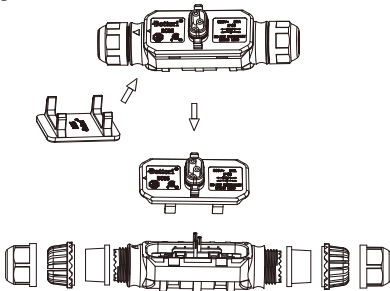

- Crimp an EN6010 non-insulated cold-pressed terminal with each cable using a hexagonal wire crimper. Thread the cables through the cover and sealing plug. Connect the L, N and PE cables to the corresponding slots, and then tighten all screws. Re-install the upper cover, ensuring that you hear a "click" sound.

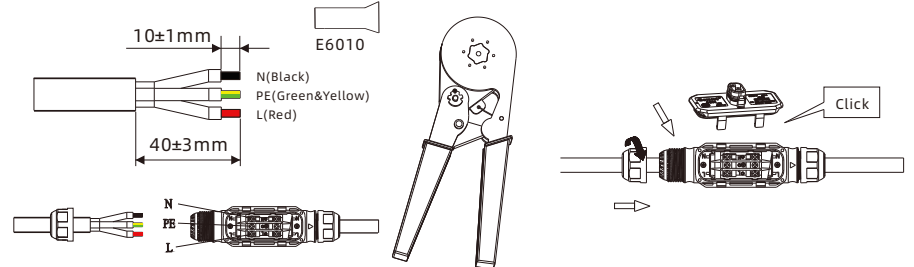

- Attach the AC bus cable to the mounting rack and secure the AC trunk connector. Connect the AC drop cable to the AC trunk connector. Make sure to hear the "click" sound as proof of a robust connection. Connect the AC bus cable to the distribution box, and wire it to the local grid network.
 - Please plug the AC trunk port cap in any vacant AC trunk port to prevent it from water and dust.
 - Please insert the AC trunk end cap to the connector at the end of the AC bus cable to avoid water or dust penetration.

Recommended number of Microinverters on the AC bus cable:

AC Bus Cable	Max. number of Microinverters			Max. Current
	NEO 600M-X	NEO 800M-X	NEO 1000M-X	
12AWG	8pcs	6pcs	4pcs	25A
10AWG	10pcs	8pcs	6pcs	30A

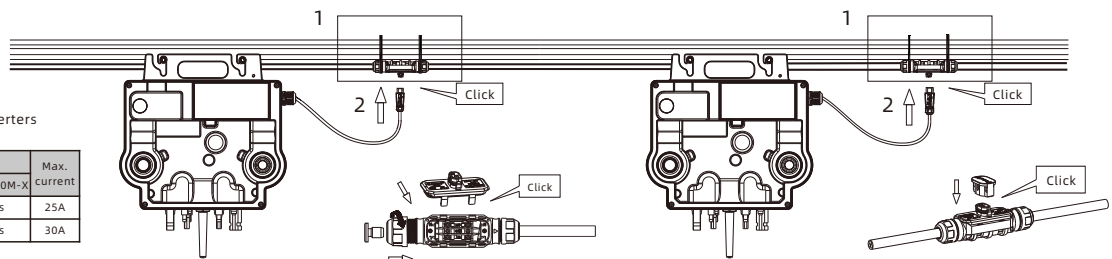

2. Connect the PV modules

- Mount the PV modules above the Microinverter.
- Connect the DC cables of PV modules to the DC input of the Microinverter.

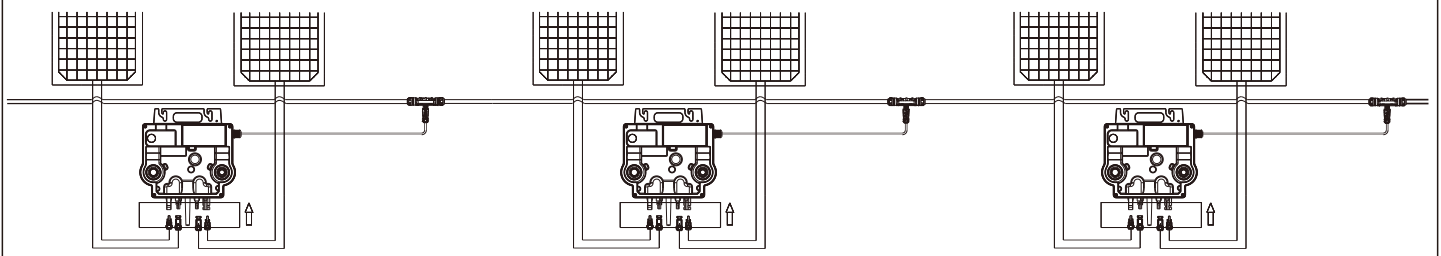

Application Scenario 2: Single-Microinverter system (balcony solar)

1. AC connection

Method 1: Use the male AC sub connector to connect the Microinverter to the distribution box.

a. Prepare the male AC sub connector.
Loosen the cover of the connector.

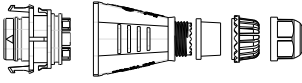

Suggested cable length:

Cable	Max. cable length		
	NEO 600M-X	NEO 800M-X	NEO 1000M-X
14AWG	40m	30m	25m
16AWG	25m	20m	15m

b. Strip each cable to a length of 13 mm and crimp the E2508 cord end terminal with the hexagonal wire crimper. Assign the L, N and PE cable to the corresponding slots, then tighten the screws and assemble the connector.

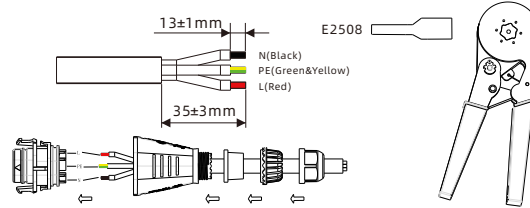

c. Fasten the nut with the AC Sub Connector Removal Tool.

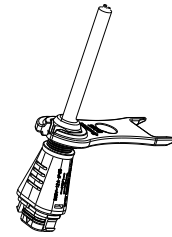

d. Connect the assembled cable with the AC drop cable of the Microinverter, ensuring that you hear a "click" sound. Then connect the other end to the distribution box to wire it to the local grid network.

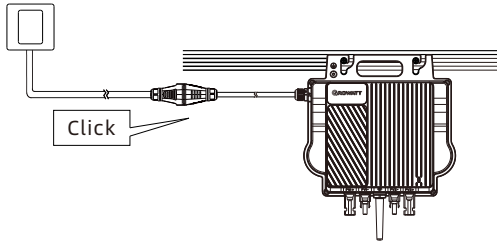

Method 2: Use the AC adapter cable to connect the microinverter to the socket. Connect the AC drop cable on the Microinverter with the AC adapter cable. Make sure that you hear a "click" sound as proof of a robust connection.

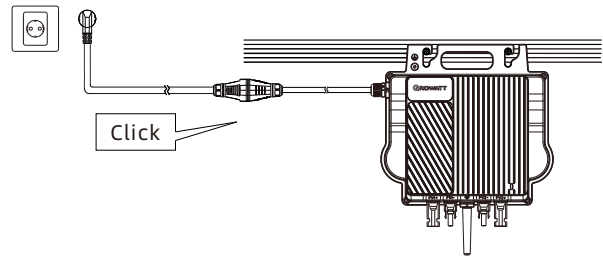

2. Connect the PV modules

a. Mount the PV modules above the Microinverter.
b. Connect the DC cables of PV modules to the DC input of the Microinverter.

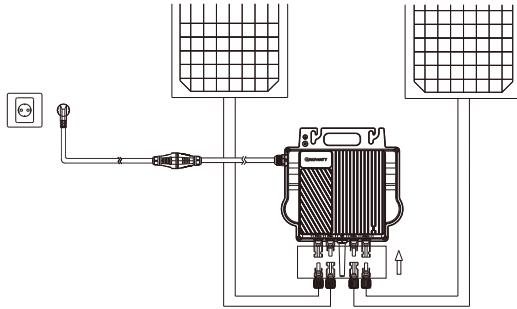

⚠ WARNING:

Ensure that the Microinverter and all DC and AC connectors are not exposed to direct sunlight, rain and snow. Verify that the grid voltage matches with the Microinverter rating.

⚠ Note:

- If the DC cable is too short for installation, use the PV extension cable to connect PV modules to the Microinverter, otherwise the PV terminals will be damaged.
- Do not connect the positive and negative DC cables into two different input channels.

Step 4 Power on the system

a. Connect to the grid
Application Scenario 1: Multi-Microinverter system (rooftop solar)
Turn on the AC breaker of the branch circuit.
Turn on the main AC breaker.
Application Scenario 2: Single-Microinverter system (balcony solar)
Method 1: Turn on the AC breaker.
Method 2: Insert the AC Adapter Cable to the socket.
b. Upon the completion of electrical connections, the system will start generating power in about two minutes.
c. Check the LED on the connector side of the microinverter.

LED Indicator Status	Description
Flashing green (on for 1s and off for 1s)	Countdown for grid-connection
Steady green	Successfully connected to the grid; the Microinverter is operating normally
Flashing green (on for 5s and off for 5s)	Successfully connected to the grid; the Microinverter fails to connect to the server
Steady red	Hardware damaged
Flashing red (on for 1s and off for 1s)	Recoverable fault caused by the field environment

Step 5 Create an Installation Map (Optional)

a. Peel the removable serial number label from each Microinverter.
b. Affix the serial number label to the respective location on the installation map, according to the layout on the roof.

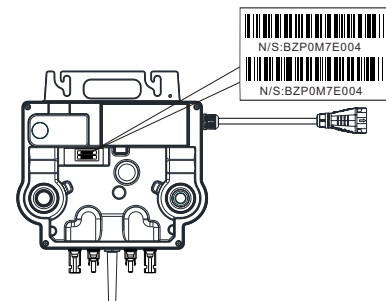

3. Datalogger Configuration

1. Download the APP

Method 1: Scan the QR code.

Method 2: Search for ShinePhone in Apple Store or Google Play.

Note: We recommend updating to the latest version when it is available.

2. Configure the datalogger

You can scan the QR code below to download the ShineWeLink Configuration Guide and obtain details about procedure to configure the datalogger.



[ShinePhone APP]



[ShineWeLink Configuration Guide]

4. Technical Data



Model	NEO 600M-X	NEO 800M-X	NEO 1000M-X
Specifications			
Input data (DC)			
Nominal voltage	16-60V		
MPP voltage range (able to generate power)	28-60V		
Max. input current per MPP tracker	18A		
Max. short-circuit current per MPP tracker	23A		
Output data (AC)			
AC nominal power	600W	800W	1000W
Max. AC apparent power	600VA	800VA	1000VA
Nominal AC voltage*	220a.c.V/230a.c.V/240a.c.V		
AC grid frequency/range*	50Hz/60Hz		
Rated output current	2.73a.c.A@220 a.c.V	3.64a.c.A@220 a.c.V	4.55a.c.A@220 a.c.V
	2.61a.c.A@230 /240a.c.V	3,48a.c.A@230 /240a.c.V	4.35a.c.A@230 /240a.c.V
Power factor(@nominal power)	0.8 leading ... 0.8 lagging		



Model	NEO 600M-X	NEO 800M-X	NEO 1000M-X
Specifications			
General data			
Dimensions (W/H/D) in mm	270mm×252mm×41.5mm		
Weight	3.1kg		
Operating temperature range	-40 °C ... +65°C		
Protection degree	Ip67 (NEMA 6)		
Wireless parameters			
Wireless frequency	868 MHz (EU) / 915 MHz		
Maximum output power	14dBm (EU) / 17dBm		
Certificates and approvals			
Grid regulation	N4105; EN50549; IEC61727, IEC62116; C10, C11; G98; CEI 0-21; IEEE1547; ORDINANCE NO.140		
Safety	CE(EMC;LVD;RED); UL1741		
Place of production	Made in China		

All specifications are subject to change without notice.

* The AC Voltage and Frequency Range may vary depending on specific country grid standard.

5. Safety

	<p>Danger to life due to lethal voltages! High voltages which may cause electric shocks are present in the conductive parts of the microinverter. Prior to performing any operations on the microinverter, disconnect the device from all power sources.</p>
	<p>Danger to life due to fire or explosion</p> <ul style="list-style-type: none"> Do not install or use in potentially flammable and explosive atmospheres. Do not allow terminator to come in contact with open flame.
	<p>Risk of burns due to hot enclosure parts</p> <ul style="list-style-type: none"> The microinverter generates heat when it is in operation. Do not touch the enclosure of the device; otherwise, it might result in burns. The microinverter should be protected against accidental contact.

	<p>Electromagnetic Radiation</p> <ul style="list-style-type: none"> Never install the microinverter near electronic sensitive devices, such as the radio, the telephone and the television. Keep a safe distance of at least 20 cm from the microinverter at all times. Growatt assumes no responsibility for compliance to EMC regulations for the entire system.
	<p>Do not throw away Do not dispose of faulty microinverters or accessories together with household waste. Please comply with the disposal regulations for electronic waste which apply at the installation site.</p>
	<p>Do not disassemble the microinverter by yourself</p> <ul style="list-style-type: none"> Do not disassemble the microinverter by yourself to avoid device damage. If you encounter any issue about the microinverter that cannot be solved, please contact Growatt supplier.

6. Declaration of conformity

This product complies with the following regulations and requirements:

- Electromagnetic Compatibility Directive:2014/30/EU (EMC)
- Radio equipment instruction:2014/53/EU(RED)
- Electrical Equipment (Safety) Regulations 2016:2014/35/EU(LVD)
- Restriction of Hazardous Substances Directive: 2011/65/EU(EU) and 2015/863 (RoHS)

You can download the Declaration of Conformity at <https://www.ginverter.com>.

7. Service and Contact

Find contact info for worldwide after-sales service at <https://www.ginverter.com/support/contact>.

Shenzhen Growatt New Energy Co., Ltd.

4-13/F, Building A, Sino-German (Europe) Industrial Park, Hangcheng Blvd, Bao'an District, Shenzhen, China

T +86 755 2747 1942

E service@ginverter.com

W www.ginverter.com



Download Manual



Growatt New Energy

GR-UM-421-A-00 (PN:044.0132200)