

SAJ



GUANGZHOU SANJING ELECTRIC CO.,LTD



Tel: (86)20 66608588 Fax: (86)20 66608589 Web: www.saj-electric.com

Add: SAJ Innovation Park, No.9, Lizhishan Road, Science City, Guangzhou High-tech Zone, Guangzhou, P.R.China

V0.2

SAJ

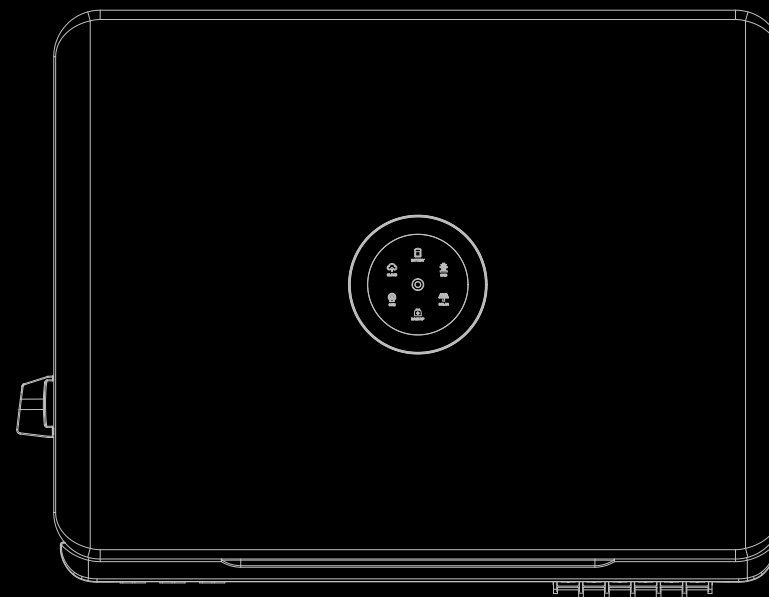

H2 Series

**SAJ HYBRID SOLAR INVERTER
USER MANUAL**

H2-5~10K-S3

Preface

Thank you for choosing SAJ products. We are pleased to provide you first-class products and exceptional service.

This manual includes information for installation, operation, maintenance, trouble shooting and safety. Please follow the instructions of this manual so that we can ensure delivery of our professional guidance and wholehearted service.

Customer-orientation is our forever commitment. We hope this document proves to be of great assistance in your journey for a cleaner and greener world.

Please check for the latest version at www.saj-electric.com.

Guangzhou Sanjing Electric Co., Ltd.

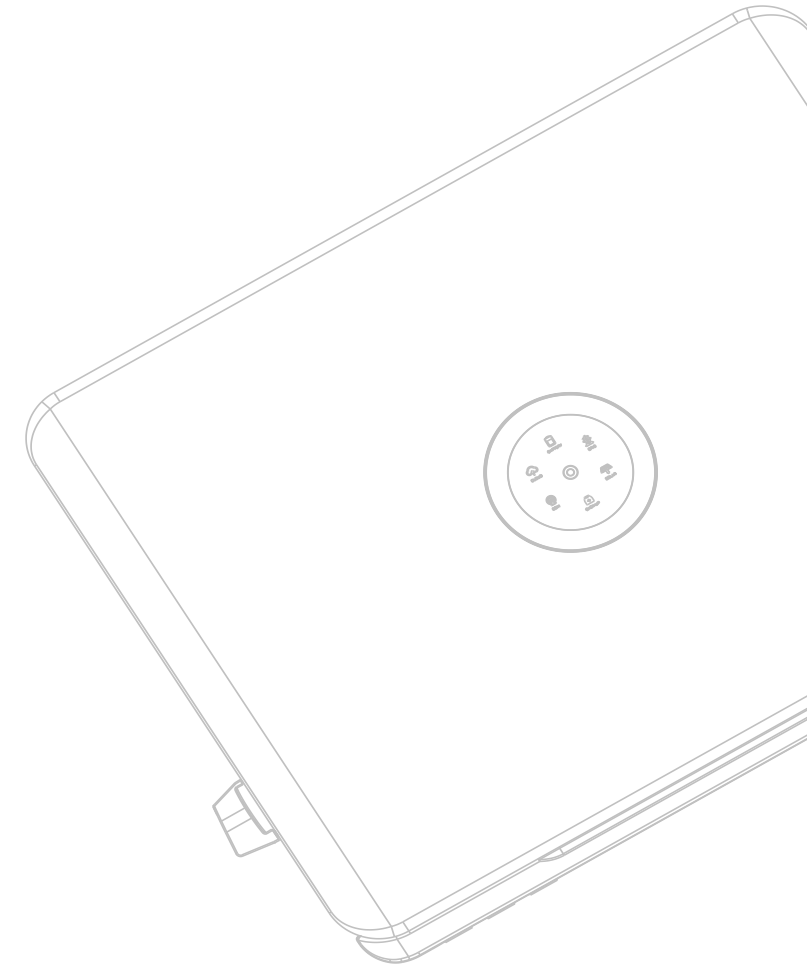

TABLE OF CONTENTS

1. SAFETY PRECAUTIONS	1
1.1 Scope of Application	2
1.2 Safety Instructions	2
1.3 Target Group	2
2. PREPARATION	3
2.1 Safety Instructions	4
2.2 Explanations Of Symbols	5
3. PRODUCT INFORMATION	7
3.1 Application Scope of Products	8
3.2 Specification for Product Model	8
3.3 Overview of Product	9
3.4 Terminals Description	9
3.5 Datasheet	11
4. INSTRUCTIONS FOR INSTALLATION	13
4.1 Unpacking and Inspection	14
4.1.1 Checking the Package	14
4.1.2 Scope of Delivery	14

4.2 Installation Method and Position	15
4.2.1 Installation Position and Clearance	15
4.2.2 Mounting Method	16
4.3 Mounting Procedure	17
4.3.1 Installation Tools	17
4.3.2 Mounting Procedure	18
5. ELECTRICAL CONNECTION	21
5.1 Additional Grounding Cable	22
5.2 AC Grid Wire and Backup Output Connection	23
5.2.1 Multiple Inverter Combinations	25
5.3 PV Side Connection	26
5.3.1 PV Connector Assembly	27
5.4 Communication Connection	30
5.5 Connection Battery COMM Cable	31
5.6 Connecting Battery Power Cable	32
5.7 Battery Connection	32
5.8 System Connection	35
5.9 System Connection Diagram	37
5.10 AFCI (Optional)	37
6. COMMISSIONING	39
6.1 Start Up and Shut Down the Energy Storage System	40
6.1.1 Start Up	40
6.1.2 Shut Down	40
6.2 Introduction of Human-computer Interface	40
6.3 Commissioning	42
6.4 eSAJ APP Connection	42
6.4.1 Account Login	42
6.4.2 Local Connection	44
6.4.3 Inverter Setting Review	46

6.5 Working Modes	47
6.5.1 Selecting Working Modes Procedures.....	47
6.5.2 Working Modes Instruction.....	47
6.6 Export Limit Setting	48
6.6.1 APP Setting.....	49
6.7 Self-test (For Italy).....	50
6.8 Setting Reactive Power Control (For Australia).....	52
6.8.1 Setup Fixed Power Factor Mode	52
6.8.2 Setup V-Watt and Volt-Var Mode.....	53
7. TRANSPORTATION and DISPOSAL	57
7.1 Transportation.....	58
7.2 Recycling and Disposal.....	58
8. ROUTINE MAINTENANCE.....	59
9. TROUBLESHOOTING and WARRANTY	61



1.1 Scope of Application

This User Manual describes instructions and detailed procedures for installing, operating, maintaining, and troubleshooting of the following SAJ products:

H2-5K-S3; H2-6K-S3; H2-7K-S3; H2-8K-S3; H2-10K-S3

1.2 Safety Instructions



DANGER

· DANGER indicates a hazardous situation which, if not avoided, will result in death or serious injury.



WARNING

· WARNING indicates a hazardous situation which, if not avoided, can result in death or serious injury or moderate injury.



CAUTION

· CAUTION indicates a hazardous condition which, if not avoided, can result in minor or moderate injury.



NOTICE

· NOTICE indicates a situation that can result in potential damage, if not avoided.

1.3 Target Group

Only qualified electricians who have read and fully understood all safety regulations in this manual can perform installation and maintenance. Operators must be aware of the high-voltage device.

SAFETY PRECAUTIONS



2.

PREPARATION



2.1 Safety Instructions

For safety, be sure to read all the safety instructions carefully prior to any works, and please observe the appropriate rules and regulations of the country or region where you installed the energy storage system.

 **DANGER**

- There is possibility of dying due to electrical shock and high voltage.
- Do not touch the operating component of the inverter; it might result in burning or death.
- To prevent risk of electric shock during installation and maintenance, please make sure that all AC and DC terminals are plugged out.
- Do not touch the surface of the equipment while the housing is wet, otherwise, it might cause electrical shock.
- Do not stay close to the equipment while there are severe weather conditions including storm, lightning, etc.
- Before opening the housing, the SAJ inverter must be disconnected from the grid and PV generator; you must wait for at least five minutes to let the energy storage capacitors completely discharged after disconnecting from power source.

 **WARNING**

- The installation, service, recycling and disposal of the inverters must be performed by qualified personnel only in compliance with national and local standards and regulations.
- Any unauthorized actions including modification of product functionality of any form may cause lethal hazard to the operator, third parties, the units or their property. SAJ is not responsible for the loss and these warranty claims.
- The SAJ inverter must only be operated with PV generator. Do not connect any other source of energy to the SAJ inverter.
- Be sure that the PV generator and inverter are well grounded in order to protect properties and persons.









 **CAUTION**

- The inverter will become hot during operation. Please do not touch the heat sink or peripheral surface during or shortly after operation.
- Risk of damage due to improper modifications.

 **NOTICE**

- The inverter is designed to feed AC power directly to the public utility power grid; do not connect AC output of the inverter to any private AC equipment.

2.2 Explanations of Symbols

Symbol	Description
	Dangerous electrical voltage This device is directly connected to public grid, thus all work to the battery shall only be carried out by qualified personnel.
	No open flames Do not place or install near flammable or explosive materials.
	Danger of hot surface The components inside the battery will release a lot of heat during operation. Do not touch metal plate housing during operating.
	Attention Install the product out of reach of children
	An error has occurred Please go to Chapter 7 "Troubleshooting" to remedy the error.
	This device shall NOT be disposed of in residential waste
	This battery module shall NOT be disposed of in residential waste
	CE Mark Equipment with the CE mark fulfills the requirements of the Low Voltage Directive and Electro Magnetic Compatibility.
	Recyclable

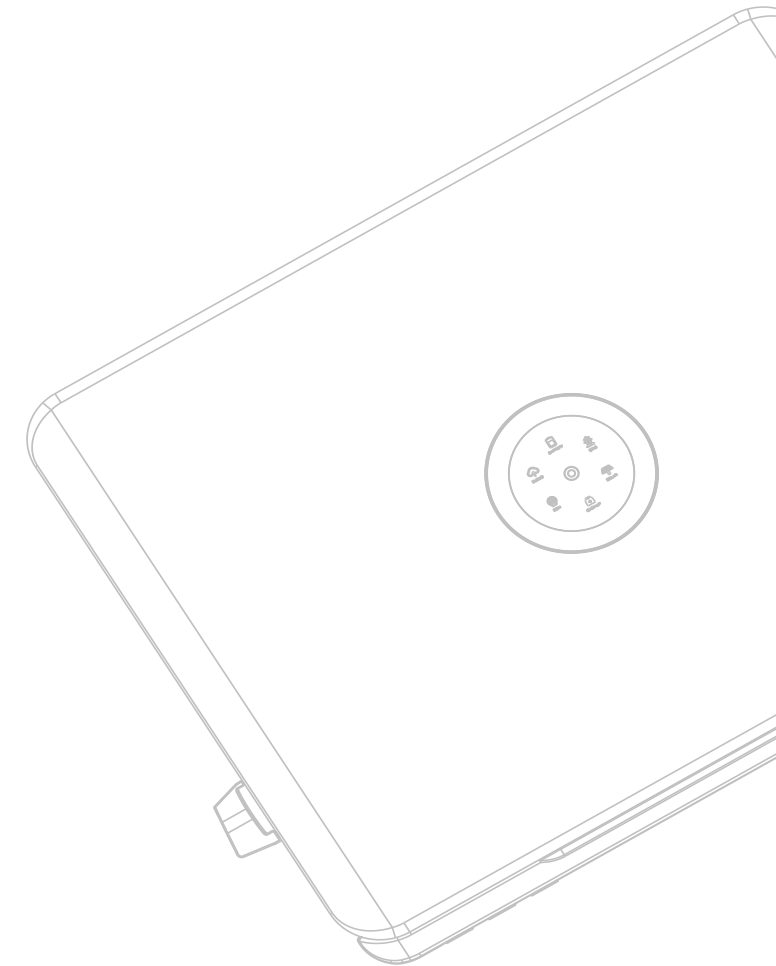

3.

PRODUCT INFORMATION



3.1 Application Scope of Products

H2 series is a hybrid photovoltaic inverter and it is applicable to both on-grid and off-grid solar systems. The energy generated by PV system will be fed to loads first, and then the surplus energy can charge the battery for later use, if there is still excess more energy, it will be exported to the grid. H2 inverter can significantly improve the self-consumption rate of solar energy and lower the dependency on grid.

3.2 Specification for Product Model

H2 - XK - S3
① ② ③

- ① H2 represents for product name.
- ② XK represents rated energy XkW of inverter, for example, 5K means 5kW.
- ③ S3 means single phase with 3MPPT

3.3 Overview of Product

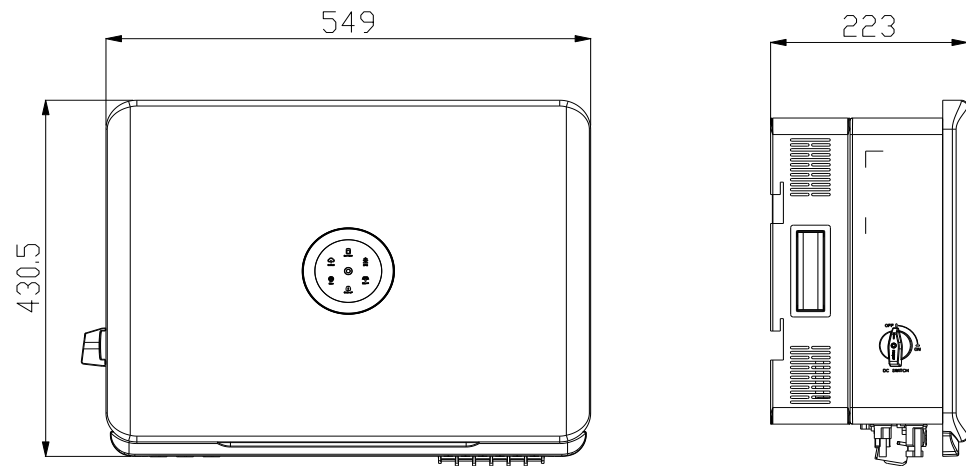

Figure 3.1
Dimensions of inverter

Code	Name
A	DC Switch
B	DC Input
C	DC Input
D	DC Input
E	Battery Input
F	BMS/ CAN/ EMS/ METER/ DRM
G	CT/ Inverter Parallel port
H	Release Valve
I	4G/ Wi-Fi
J	Ground Connection
K	Grid
L	Backup

Table 3.1
Terminals description

3.4 Terminals Description

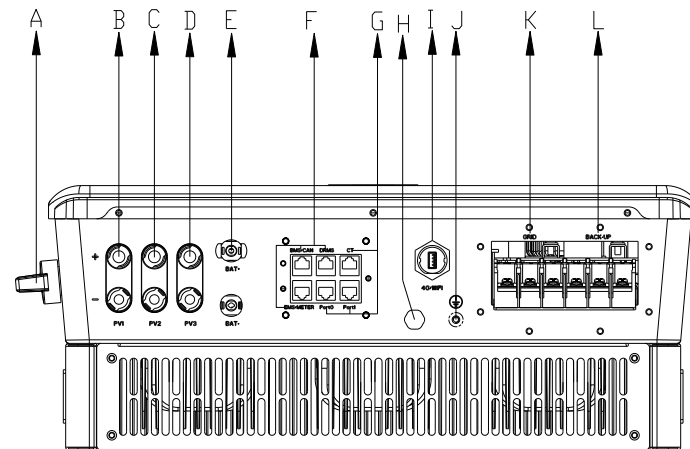

Figure 3.2
Electrical interface of H2 Inverter

3.5 Datasheet

Model	H2-5K-S3	H2-6K-S3	H2-7K-S3	H2-8K-S3	H2-10K-S3
DC Input					
Max. PV Array Power [Wp]@STC	7500	9000	10500	12000	15000
Max. DC Voltage [V]	600				
MPPT Voltage Range [V]	90~550				
Rated DC Voltage [V]	360				
Start Voltage [V]	100				
Max. DC Input Current [A]	16/16/16				
Max. DC Short Circuit Current [A]	19.2/19.2/19.2				
No. of MPPT	3				
Battery Parameters					
Battery Type	LiFePO4				
Battery Voltage Range [V]	85~450				
Max. Charging/Discharging Current [A]	50/50				
AC Output [On-grid]					
Rated AC Power [W]	5000	6000	7000	8000	10000
Max. Apparent Power [VA]	5500	6600	7700	8800	10000
Rated Current [A]	21.7	26.1	30.4	34.8	43.5
Max. AC Output Current to Utility Grid [A]	25	30	35	40	45.5
Current Inrush[A]	150				
Max. AC Fault Current[A]	130				
Max. AC Over Current Protection[A]	63	75	88	100	100
Rated AC Voltage/Range [V]	L+N+PE, 220, 230, 240/180~280				
Rated Output Frequency/Range [Hz]	50,60/45~55,55~65				
Power Factor [cos φ]	0.8 leading ~ 0.8 lagging				
Total Harmonic Distortion [THDi]	<3%				
AC Input [On-grid]					
Rated AC Voltage/Range [V]	L+N+PE, 220, 230, 240/180~280				
Rated Input Frequency [Hz]	50,60				
Max. Input Current [A]@230Vac	43.5	52.2	60.9	69.6	69.6
AC Output [Back-up]					
Max. Output Power [VA]	5000	6000	7000	8000	10000
Max. Output Current [A]	22.7	27.3	31.8	36.4	45.5

Model	H2-5K-S3	H2-6K-S3	H2-7K-S3	H2-8K-S3	H2-10K-S3
Peak Output Apparent Power [VA]	6000,60s	72000,60s	8400,60s	9600,60s	12000,60s
Rated AC Voltage/Range [V]	L+N+PE, 220, 230, 240/180~280				
Rated Output Frequency/Range [Hz]	50,60/45 ~ 55,55 ~ 65				
Output THDv (@ Linear Load)	<3%				
Efficiency					
Max. Efficiency	97.6%				
Euro Efficiency	97.0%				
Protection					
Battery Input Reverse Polarity Protection	Integrated				
Over Load Protection	Integrated				
AC Short Circuit Current Protection	Integrated				
DC Surge Protection	Integrated				
AC Surge Protection	Integrated				
Anti-islanding Protection	Integrated				
AFCI Protection	Optional				
RSD Protection	Optional				
Interface					
PV Connection	MC4/D4(Optional)				
AC Connection	Plug-in connector				
Battery Connection	Quick connector				
Display	LED+APP				
Communication	Wi-Fi/Ethernet/4G(Optional)				
General Parameters					
Topology	Non-isolated				
Operating Temperature Range	-40°C to +60°C (45°C and above with derating)				
Cooling Method	Natural Convection				
Ambient Humidity	0-100% Non-condensing				
Altitude	4000m (>3000m Power Derating)				
Noise [dBA]	<35				
Ingress Protection	IP65				
Dimensions [H*W*D] [mm]	430.5* 549 *223				
Weight [kg]	26				
Warranty [Year]	Refer to the warranty policy				
Standard	CEI 0-21, VDE4105-AR-N, VDE0126-1-1, EN50438, G98, G99, EN50549, AS4777.2, IEC62109-1&-2, IEC62040-1, EN61000-6-1/2/3/4				

4.

INSTRUCTIONS FOR INSTALLATION



4.1 Unpacking and Inspection







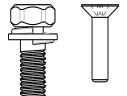
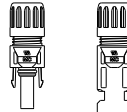

4.1.1 Checking the Package

Although SAJ's products have thoroughly tested and checked before delivery, there is possibility that the products may suffer damages during transportation. Please check the package for any obvious signs of damage, and if such evidence is present, do not open the package and contact your dealer as soon as possible.

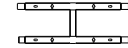
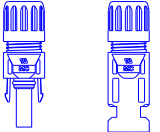
4.1.2 Scope of Delivery

Please contact after sales if there are missing or damaged components.

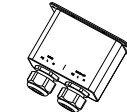
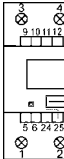
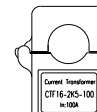
Inverter Package

					
H2 Inverter*1	Hexagon Philips bolt group M5*12 1PCS Sunk screw M4*10 12PCS	PV terminal 3*2	Documents	Waterproof communication terminal block*1	Rear Panel*1
					
Battery terminal 1*2	AC terminal*6	M6*50 screw suite*4	Communication module*1 (Optional)	Waterproof AC terminal block*1	Smart meter*1
					
Current transformer*1	120Ω resistor*1	Meter COMM cable*1 (1000mm)			

The documents include the user manual and packaging list.

4.2 Installation Method and Position

4.2.1 Installation Position and Clearance

This device is cooled by natural convection and suggested an indoor installation or an installation under a sheltered place to prevent the product from exposure to direct sunlight, rain and snow erosion.

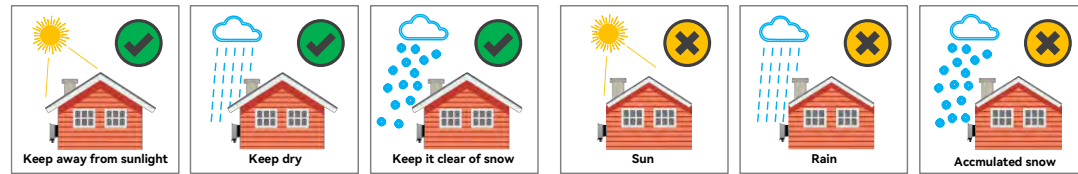

Figure 4.1
Installation location

Please reserve enough clearance around the product to ensure a good air circulation at the installation area. Because poor air ventilation will affect the working performance of internal electronic components and shorten the service life of the system.

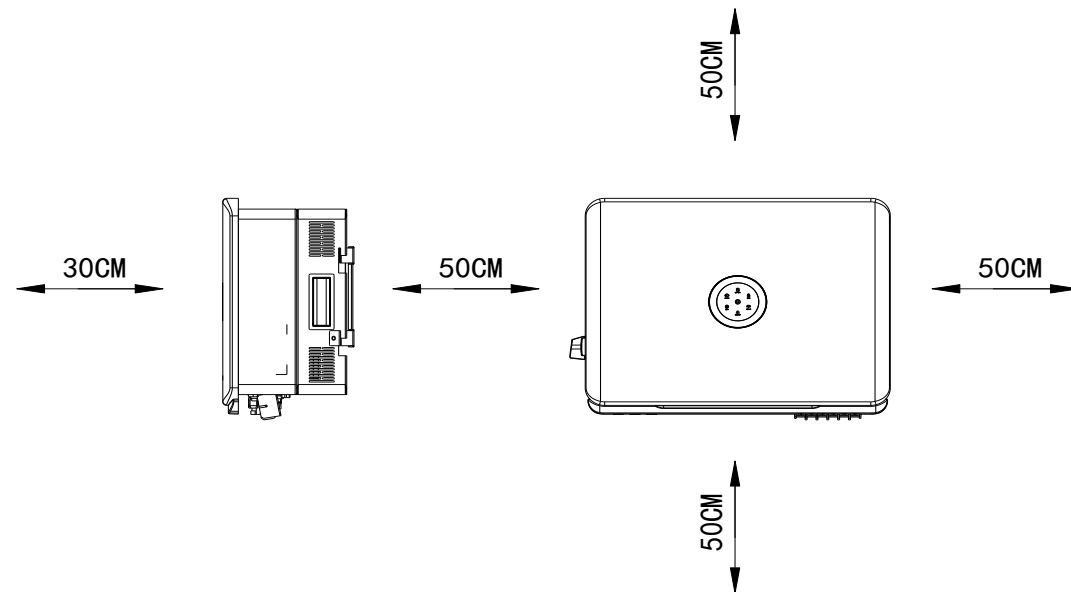

Figure 4.2
Installation clearance

4.2.2 Mounting Method

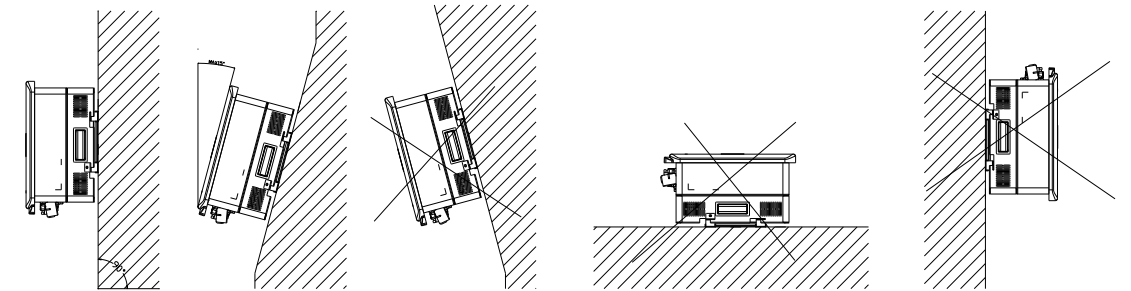

Figure 4.3
Mounting method

- ① The equipment employs natural convection cooling, and it can be installed indoor or outdoor.
- ② Mount vertically. Never install the device tilted forwards, sideways, horizontally or upside down.
- ③ When mounting the device, please consider the solidity of wall for product, including accessories, make sure the wall has enough strength to hold the screws and bear the weight of products. Please ensure the mounting bracket mounted tightly.

Installation Environment Requirements

- The installation environment must be free of inflammable or explosive materials.
- Install the device away from heat source.
- Do not install the device at a place where the temperature changes extremely.
- Keep the device away from children.

- Do not install the device at daily working or living areas, including but not limited to the following areas: bedroom, lounge, living room, study, toilet, bathroom, theater and attic.
- When installing the device at the garage, please keep it away from drive way.
- Keep the device from water sources such as taps, sewer pipes and sprinklers to prevent water seepage.
- The product is to be installed in a high traffic area where the fault is likely to be seen.

Note: When installing outdoors, the height of the device from the ground should be considered to prevent the device from soaking in water. The specific height is determined by the site environment.

4.3 Mounting Procedure

4.3.1 Installation Tools

Installation tools include but are not limited to the following recommended ones. Please use other auxiliary tools on site if necessary.

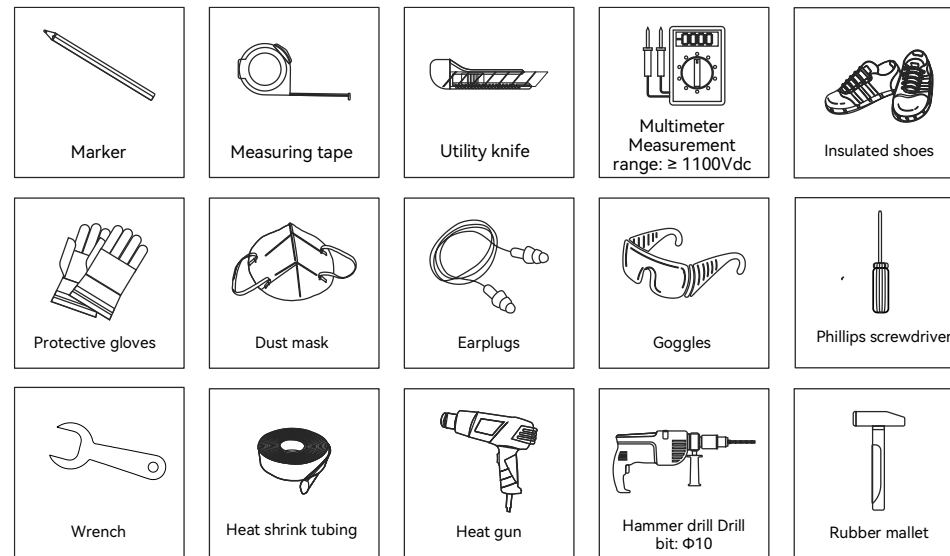

4.3.2 Mounting Procedures

1. Mark the Positions of the Drill Holes on the Rear Panel

The mounting position should be marked as shown in the following figure.

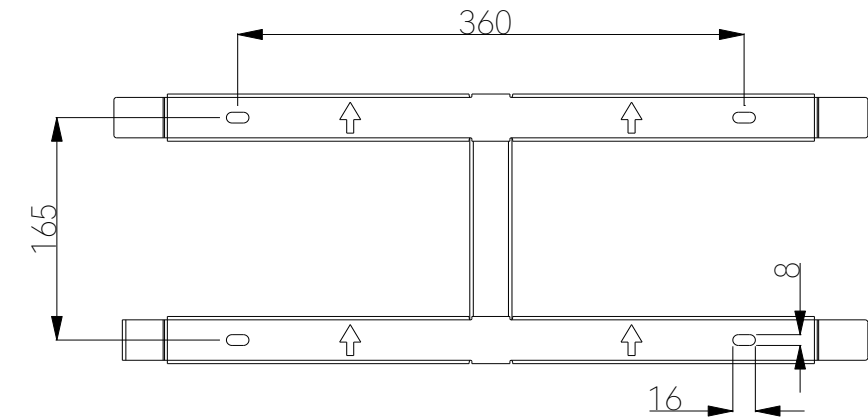

Figure 4.4
Mark positions

2. Drill Holes and Place the Expansion Tubes

Drill 4 holes in the wall (in conformity with the position marked in Figure 4.4), and then place expansion tubes in the holes using a rubber mallet.

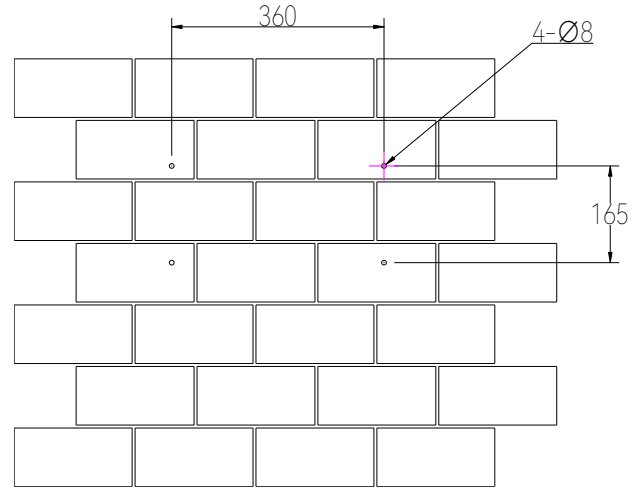

Figure 4.5
Drill holes for installation

3. Secure the Screws and the Rear Panel

The panels should be secured onto the mounting position by screws as shown in Figure 4.6.

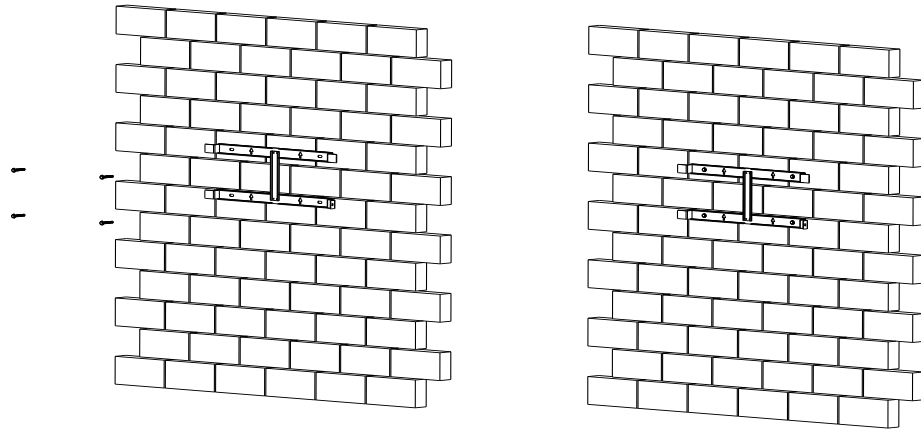

Figure 4.6
Secure the panel

4. Mount the Inverter

Carefully mount the inverter into the rear panel as shown in Figure 4.7. Make sure that the rear part of the equipment is closely mounted into the rear panel.

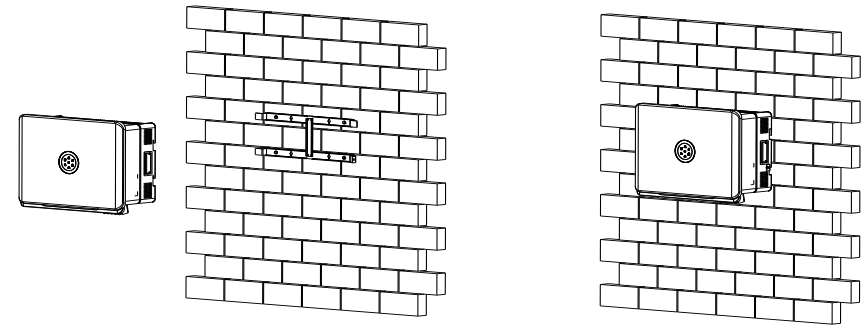

Figure 4.7
Mount the inverter

5.

ELECTRICAL
CONNECTION

5.1 Additional Grounding Cable

Electrical connection must only be operated by professional technicians. Before connection, necessary protective equipment must be employed by technicians, including insulating gloves, insulating shoes and safety helmet.

**WARNING**

· Connect this additional grounding cable before other electrical connection.

Note: The additional cable and OT/DT terminal should be prepared by user themselves.

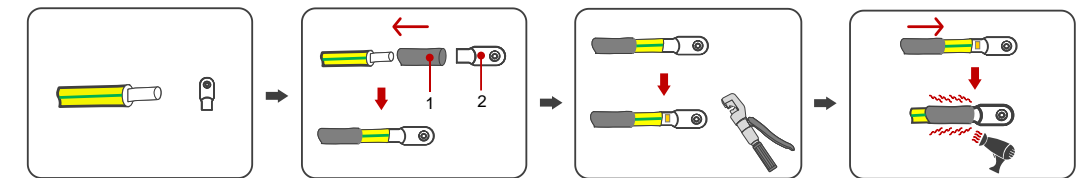

Figure 5.1
Preparing additional grounding cable

1. Heat shrink tubing 2. OT/DT terminal

Remove the screw of grounding terminal and secure the additional grounding cable by insert a screw into the screw hole in the OT/DT terminal. Connect the grounding cables as the following diagram.

Note: A 6 mm² conductor cross-sectional area of cable is recommended for additional grounding cable.

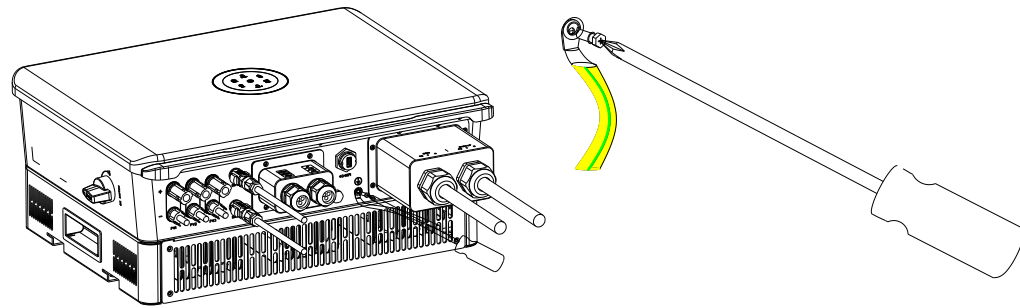

Figure 5.2
Connecting the additional
grounding cable

5.2 AC Grid Wire and Backup Output Connection

Cable cross-sectional area (mm ²)	
Range	Recommend
13~21	16
Additional grounding cable cross-sectional area (mm ²): 6	

Table 5.1
Recommended specifications of AC cables

Note: If the grid-connection distance is too far, please select an AC cable with larger diameter as per the actual condition.

Procedure:

Step 1: Open the waterproof cover, feed the AC cable through the AC waterproof hole.

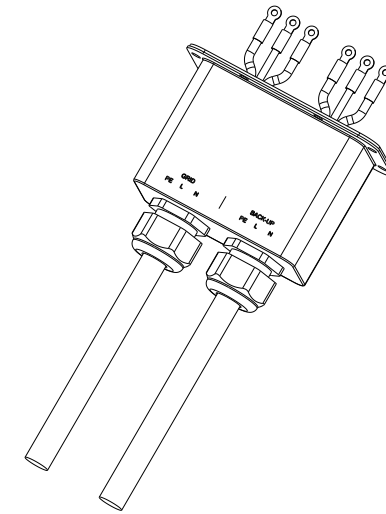

Figure 5.3
Thread the cables

Step 2: Fix the cables according to conductor marks of L, N and PE.

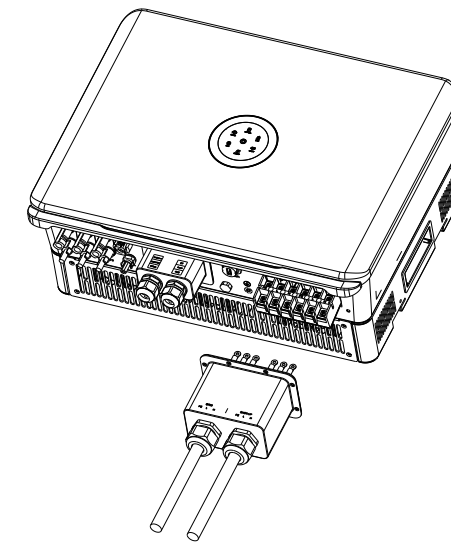

Figure 5.4
Connect the Cables

Step 3: Secure all parts of the grid and backup connector tightly.

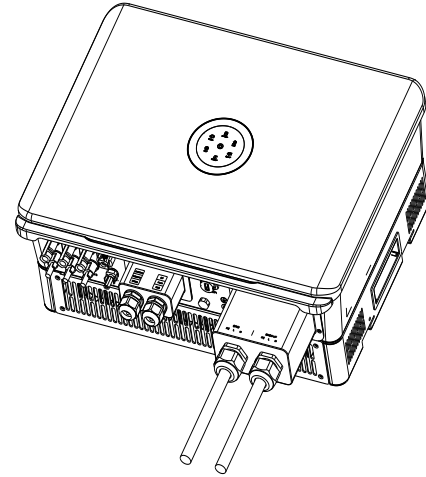
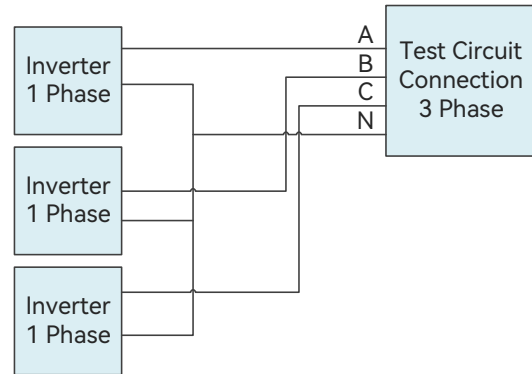

Figure 5.4
Screw the Connector

Step 4: During off grid operation time, PE line at the BACK-UP end will remain to be connected with the PE line at the power grid end inside the inverter. (Only applicable to market in Australia)

5.2.1 Multiple Inverter Combinations



The inverter should not be installed in multiple phase combinations. If any such multiple inverter combination is not tested, it should not be used or external devices should be used in accordance with the requirements of AS/NZS 4777.1

5.2.2 Earth Fault Alarm

This inverter complies with IEC 62109-2 clause 13.9 for earth fault alarm monitoring. If an Earth Fault Alarm occurs, the ring light will be lit up in red and error code <31> will be displayed on LED panel 1 until the error being solved and inverter functioning properly.

Note: The inverter cannot be used with functionally earthed PV Arrays.

5.2.3 External AC Circuit Breaker and Residual Current Device

Please install a circuit breaker to ensure the inverter is able to disconnect from grid safely. The integrated leakage current detector of inverter is able to detect the real time external current leakage. When a leakage current detected exceeds the limitation, the inverter will be disconnected from grid quickly.

The inverter does not require an external residual current device, as it has integrated with a RCMU. If local regulations require the application of external residual current device, either type A or type B RCD is compatible with the inverter. The action current of external residual current device should be 300mA.

Inverter type	Recommended breaker specification
H2-5~10K-S3	100A
Notice: Do not connect multiple inverters to one AC circuit breaker.	

Table 5.2
Recommended circuit breaker specification

5.3 PV Side Connection

⚠ WARNING

Make sure the PV array is well insulated to ground before connecting it to the inverter.

Conductor cross-sectional area of cables (mm ²)		Conductor material
Scope	Recommended value	Outdoor multi-core copper wire cable, complying with 600Vdc
4.0~6.0	4.0	

Table 5.3
Recommended specifications of DC cable

5.3.1 PV Connector Assembly

 WARNING
<p>Dangerous to life due to electric shock when live components or DC cables are touched.</p> <ul style="list-style-type: none"> · The PV panel string will produce lethal high voltage when exposed to sunlight. Touching live DC cables results in death or lethal injuries. · DO NOT touch non-insulated parts or cables · Disconnect inverter from voltage sources. · DO NOT disconnect DC connectors under load. · Wear suitable personal protective equipment for all work.

DC connector is made up of positive connector and the negative connector



Figure 5.5
Positive connector
& Negative connector

 NOTICE
<ul style="list-style-type: none"> · Please place the connector separately after unpacking in order to avoid confusion for connection of cables. · Please connect the positive connector to the positive side of the solar panels, and connect the negative connector to the negative side of the solar side. Be sure to connect them in right position.

Connecting Procedures:

1. Loosen the lock screws on positive and negative connector.
2. Strip the insulation of the positive and negative cables with 8-10mm length.

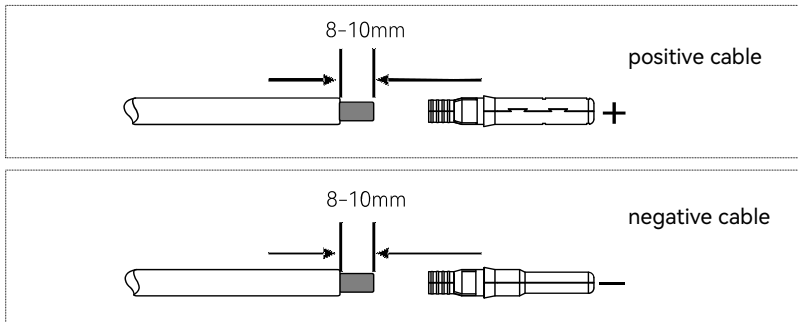

Figure 5.6
Striping off the insulation skin of cables

3. Assembly the positive and negative cables with corresponding crimping pliers.

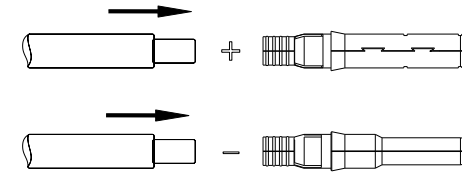

Figure 5.7
Inserting cables to lock screws

4. Insert the positive and negative cable into positive and negative connector. Gently pull the cables backward to ensure firm connection.

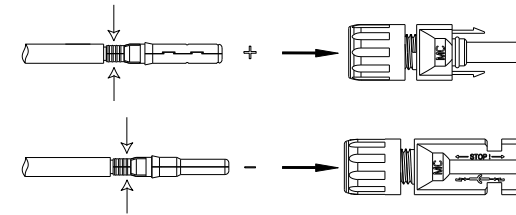

Figure 5.8
Inserting crimped cables to connectors

5. Fasten the lock screws on positive and negative connectors.

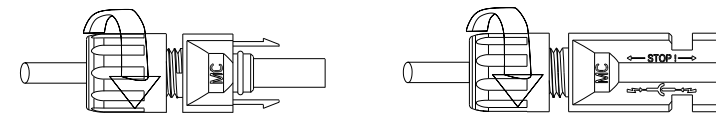

Figure 5.9
Securing the connectors

6. Make sure the DC switch is at OFF position

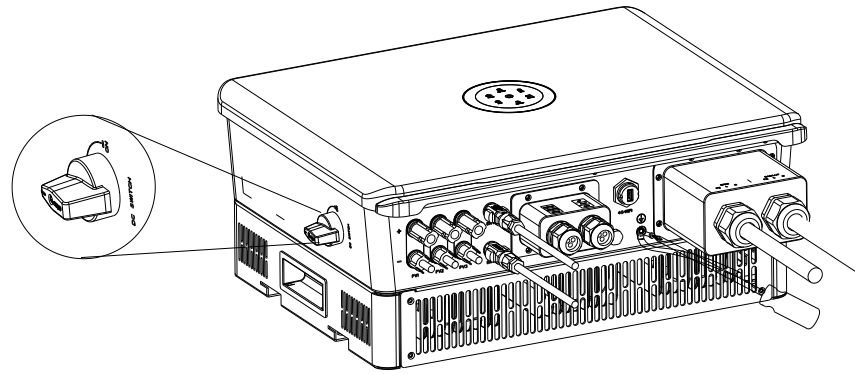

Figure 5.10
DC switch

7. Connect the positive and negative connectors into positive and negative DC input terminals of the inverter, a “click” should be heard or felt when the contact cable assembly is seated correctly.

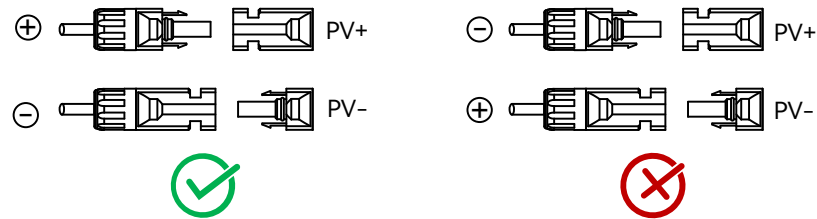

Figure 5.11
Plug in PV connectors

5.4 Communication Connection

Notes:

1. Confirm that the DC switch is OFF during installation to avoid short circuit caused by wrong operation during battery wiring.
2. Please use the battery cable in original package.

Attention: The meter can only be connected to the RS485-A1+ and RS485-B1- signal ports.

EMS/METER	
1	RS485-A1+
2	RS485-B1-
3	NC
4	NC
5	NC
6	NC
7	RS485-A2+
8	RS485-B2-

CT	
1	R/CT.I+
2	R/CT.1-
3	NC
4	NC
5	NC
6	NC
7	NC
8	NC

DRM	
1	DRM1/5
2	DRM2/6
3	DRM3/7
4	DRM4/8
5	RefGen
6	Com/DRM0
7	V+
8	V-

CAN/BMS	
1	NC
2	NC
3	NC
4	CANH
5	CANL
6	NC
7	NC
8	NC

PORT0	
1	NC
2	NC
3	NC
4	NC
5	NC
6	NC
7	NC
8	NC

PORT1	
1	NC
2	NC
3	NC
4	NC
5	NC
6	NC
7	NC
8	NC

Thread the communication cable through the waterproof cable gland and connect to the corresponding port.

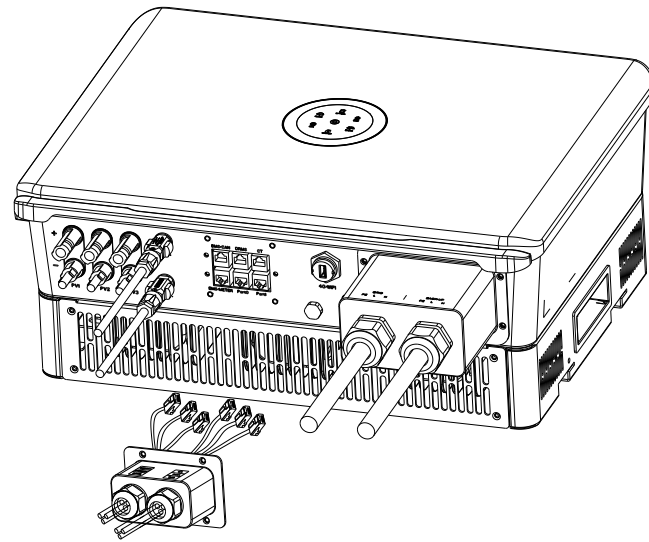

Figure 5.12
Communication cable connection

5.5 Communication Module Installation

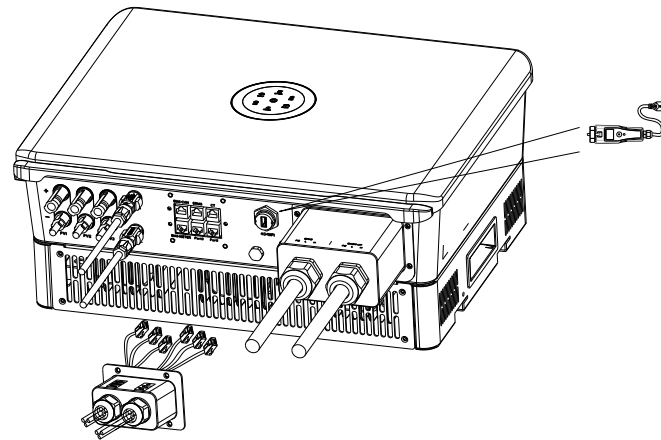

Figure 5.13
4G/WiFi port

Plug in the communication module to 4G/WIFI port and secure the module by rotating the nut.

1. 4G/Wi-Fi port could be externally connected with eSolar 4G module, eSolar Wi-Fi module or eSolar AIO3 module, for operation in details please refer to communication module Quick Installation Guide in <https://www.saj-electric.com/>.

5.6 Connecting Battery Power Cable



- Power off the battery system before connecting the power cable to avoid high voltage danger
- The electrical connection of high voltage battery systems must be operated by qualified technicians in accordance with local and national power grid standards and regulations.

5.7 Battery Connection

If lithium battery is connected, it is not required to install a breaker between battery and inverter.

Cable Cross-sectional area (mm ²)	
Range	Recommend
8-10	8

Table 4.4
Recommended specifications of DC cables

Procedure:

1. Open the waterproof cover, then feed the battery cable through the AC waterproof hole.

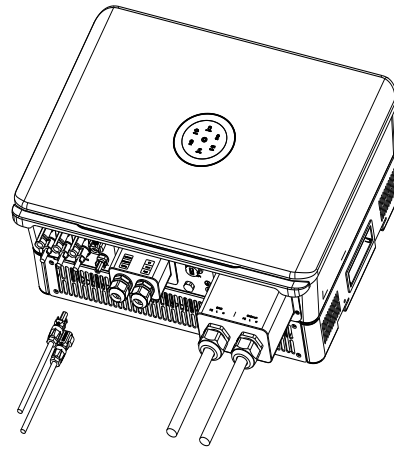

Figure 5.14
Open the waterproof cover

2.Strip off the insulation skin of DC cable, the core is exposed to 15mm,

- Open the spring using a 3mm wide bladed screwdriver
- Carefully insert the stripped wire all the way in
- The wire ends have to be visible in the spring.
- Close the spring. Make sure that the spring is snapped in
- Push the insert into the sleeve
- Tighten the cable gland

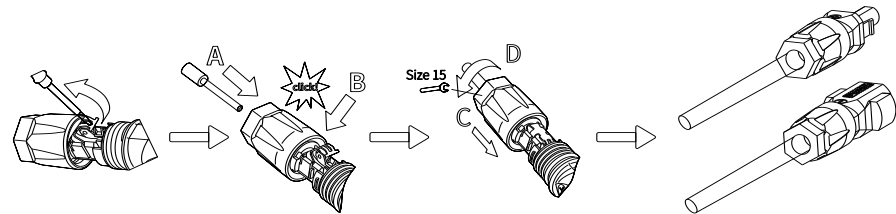

Figure 5.15
Battery Terminal

3.Fix the battery cable on the battery copper terminal by positive and negative in order.

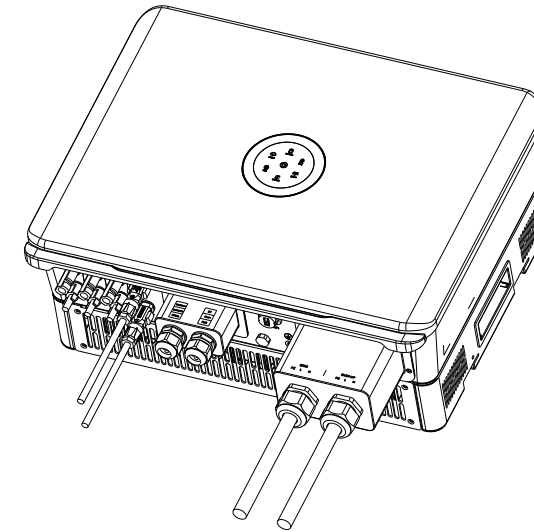

Figure 5.15
Connecting battery power cables

4. Follow the clause 5.4 communication connection to check or install the BMS connection between inverter and battery in proper port.

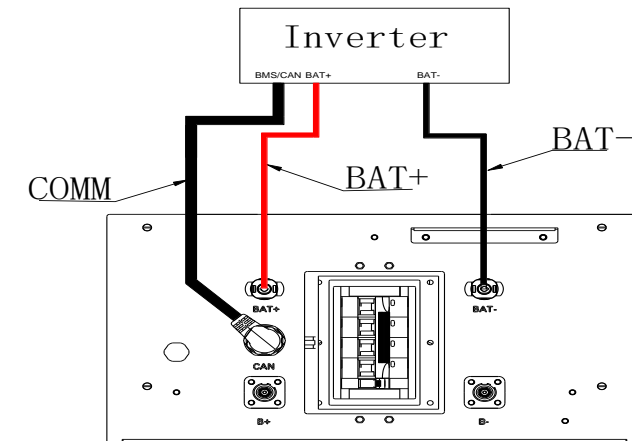
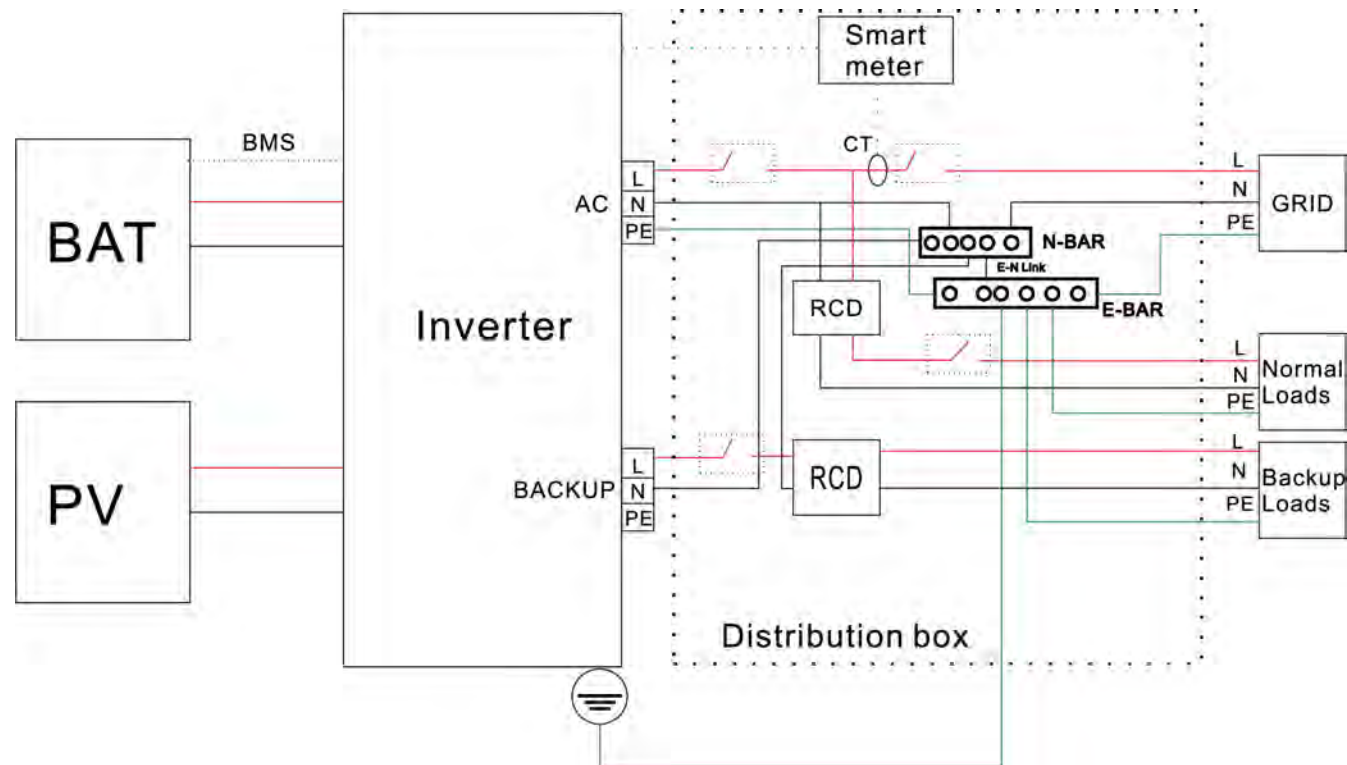

Figure 5.16
communication connection

5.8 System Connection

The system connection in Germany, Australia and New Zealand is as below, the neutral cable of AC and backup side must be connected together for the safety reason.
Note: DO NOT connect the PE terminal of BACKUP side.



The system connection for grid system without special requirements is as below.

Note: The backup PE line and earthing bar must be grounded properly. Otherwise, backup function may be inactive during blackout.

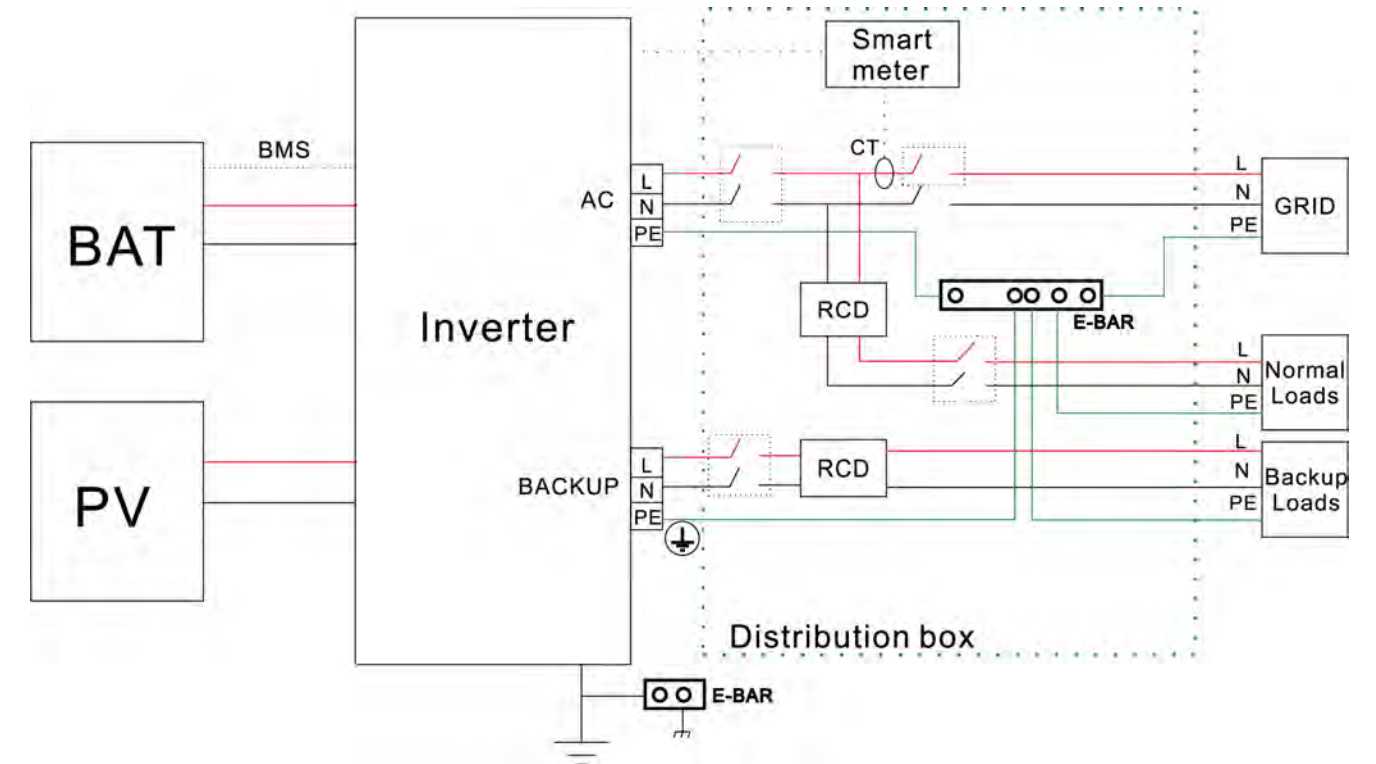

5.9 System Connection Diagram

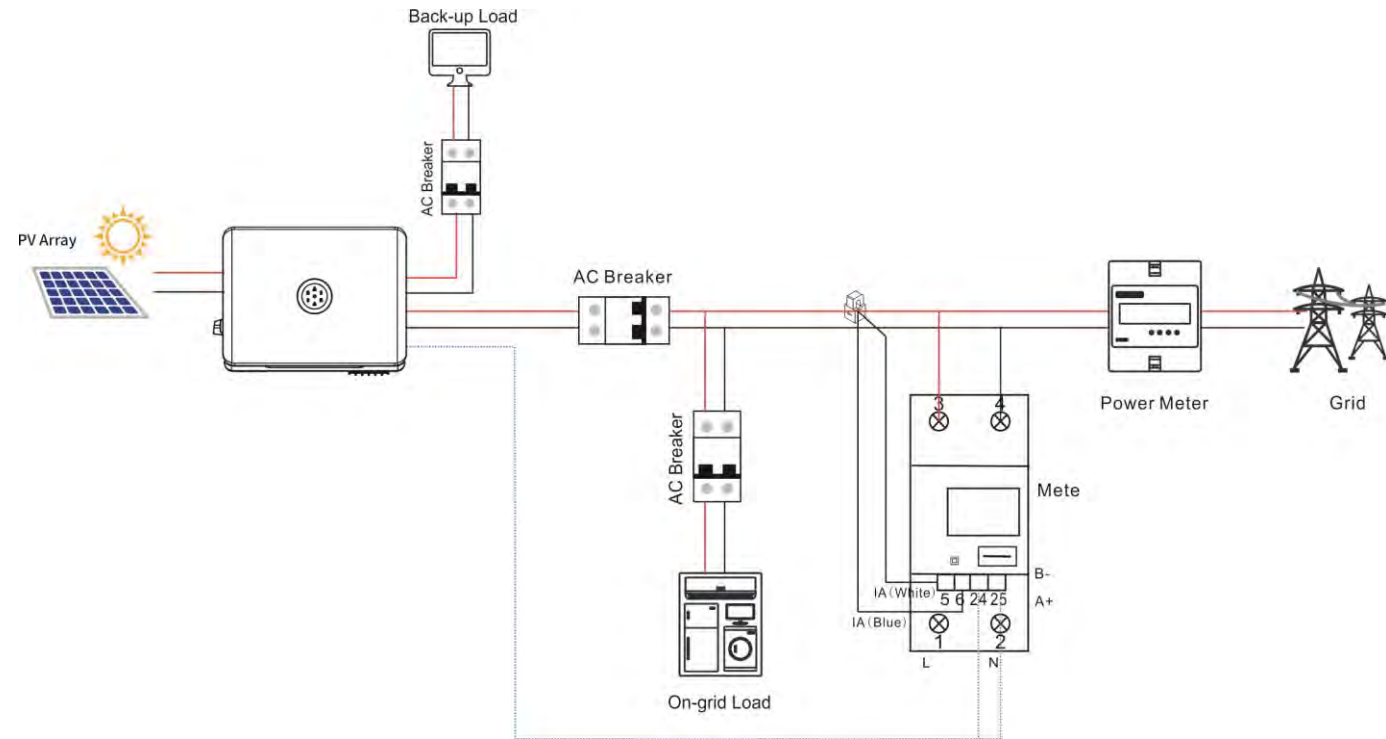

Note: If the RS485 cable length between inverter and meter is longer than 20m, please install the 120Ω resistor in port 24&25 of the meter.

5.10 AFCI (Optional)

The inverter is equipped with arc-fault circuit interrupter (AFCI). With AFCI protection, when there is an arc signal on the DC side due to aging of the cable or loose contact, inverter can quickly detect and cut off the power to prevent fire, making the PV system run more safely.

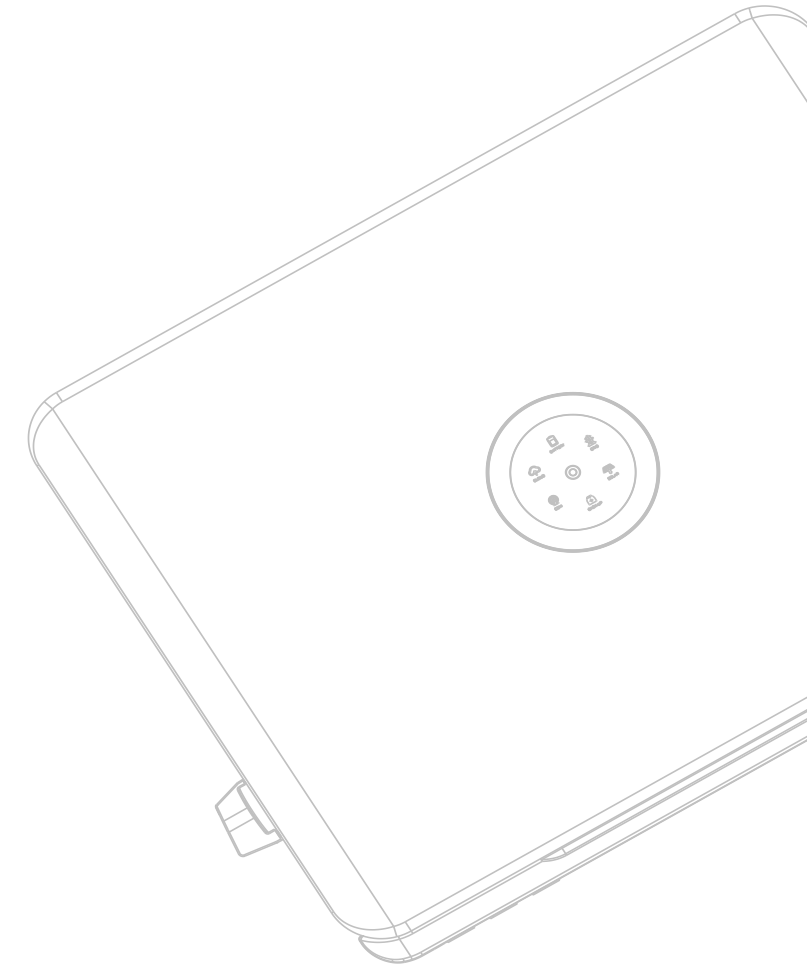

6.

COMMISSIONING



6.1 Start Up and Shut Down the Energy Storage System

6.1.1 Start Up

Step 1: Turn on the circuit breaker

Step 2: Press and hold the main switch for 2-3s, until the display is on

6.1.2 Shut Down

Automatically shut down, when the solar light intensity is not strong enough during sunrise and sunset or the output voltage of photovoltaic system is less than the minimum input power of inverter, inverter will shut down automatically.

Shut down manually, disconnect AC side circuit breaker first, if multiple inverters are connected, disconnect the minor circuit breaker prior to disconnection of main circuit breaker. Disconnect the DC switch after inverter has reported grid connection lost alarm.

6.2 Introduction of Human-Computer Interface

System commissioning

After the wiring is completed, please refer to the inverter manual for system commission and operation.

Note: Turn on the circuit breaker and main switch when using battery.

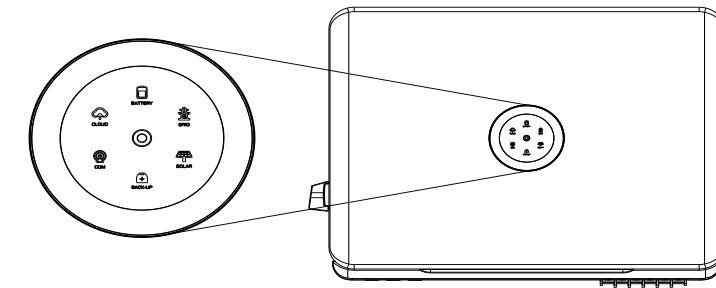













Figure 6.3
Human-computer interface

LED indicator	Status	Description
	LED off	Inverter power off
	Breathing	Inverter is at initial state or standby state
	Solid	Inverter running properly
	Breathing	Inverter is upgrading
	Solid	Inverter is faulty
 System	Solid	Importing electricity from grid
	On 1s, off 1s	Exporting electricity to grid
	On 1s, off 3s	Not importing and exporting at all
	Off	Off-grid
 Battery	Solid	Battery is discharging
	On 1s, off 1s	Battery is charging
	On 1s, off 3s	SOC low
	Off	Battery is disconnected or inactive
 Grid	Solid	Connected to grid
	On 1s, off 1s	Counting down to grid connection
	On 1s, off 3s	Grid is faulty
	Off	No grid
 PV	Solid	PV array is running properly
	On 1s, off 1s	PV array is faulty
	Off	PV array is not operating
 Backup	Solid	AC side load is running properly
	On 1s, off 1s	AC side load overload
	Off	AC side is turned off
	Solid	Both BMS and meter communication are good
	On 1s, off 1s	Meter communication is good, BMS communication is lost

LED indicator	Status	Description
Communication	On 1s, off 3s	Meter communication is lost, BMS communication is good
	Off	Both meter and BMS communication are lost
 Cloud	Solid	Connected
	On 1s, off 1s	Connecting
	Off	Disconnected

Table 6.1
Interface description

Note: One breathing cycle is 6 seconds.

6.3 Commissioning

- (1) Connect the AC circuit breaker
- (2) Connect the DC circuit breaker between inverter and battery (if applicable)
- (3) Turn ON the battery (if applicable)
- (4) Turn ON the DC switch on the inverter
- (5) Install the communication module into the inverter
- (6) Setup the initial setting for inverter on eSAJ Home
- (7) Observe the LED indicators on the inverter to ensure the inverter is running properly

6.4 eSAJ APP Connection

6.4.1 Account Login

- Step 1: Log in to eSAJ Home, if you do not have an account, please register first.
- Step 2: Go to the "Tool" interface and select "Remote Configuration"
- Step 3: Click on "Bluetooth" and activate the Bluetooth function on your phone, then click on "Next"
- Step 4: Choose your inverter according to your inverter SN's tail numbers
- Step 5: Click on the inverter to enter inverter setting
- Step 6: Select the corresponding country and grid code for

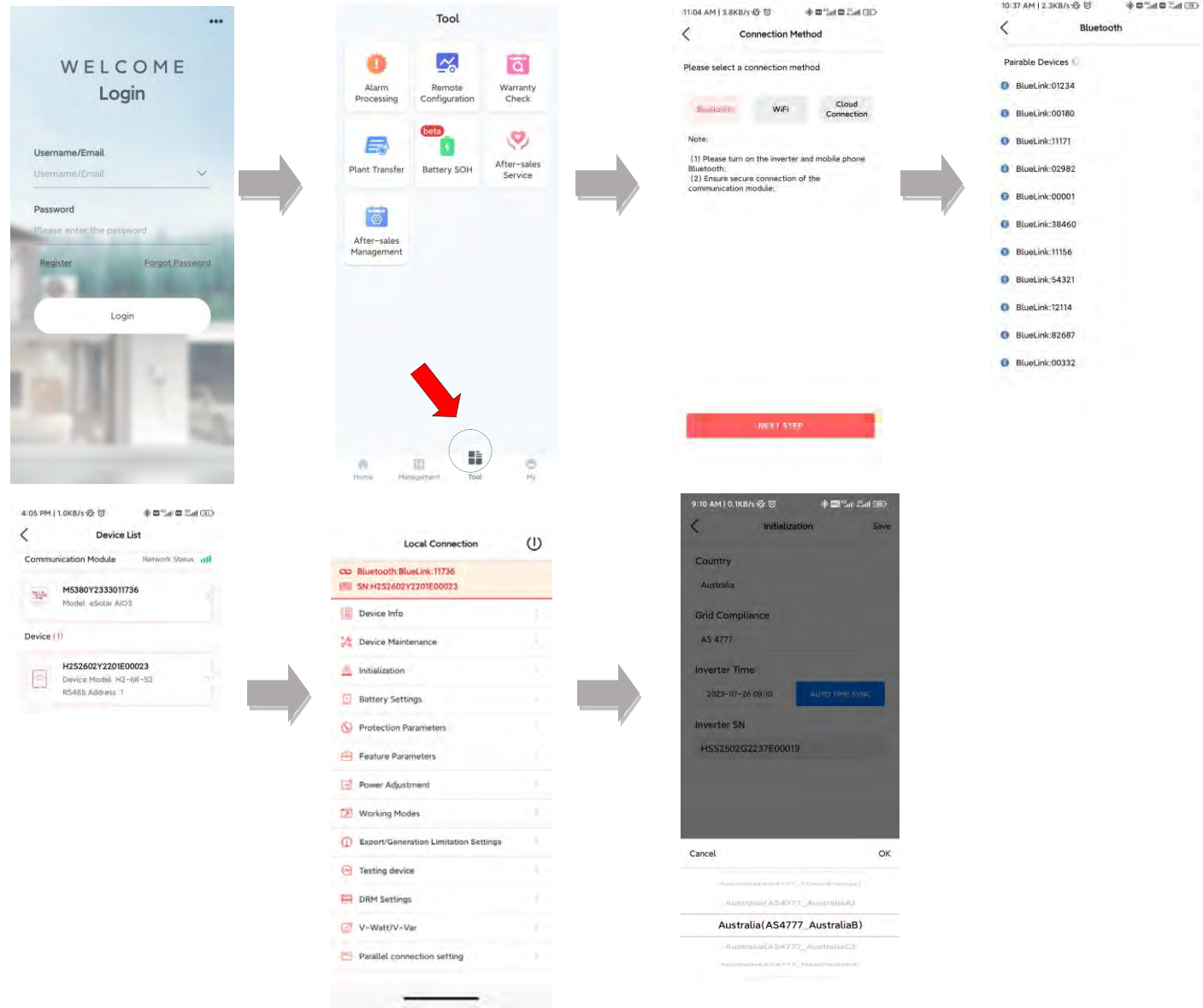

6.4.2 Local Connection

- Step 1: Open eSAJ APP and click on the dot icon on the top right corner
- Step 2: Select "Local Connection"
- Step 3: Enter password "123456"
- Step 4: Click on "Bluetooth" and activate the Bluetooth function on your phone, then click on "Next"
- Step 5: Choose your inverter according to your inverter SN's tail numbers
- Step 6: Click on the inverter to enter inverter setting
- Step 7: Select the corresponding country and grid code for

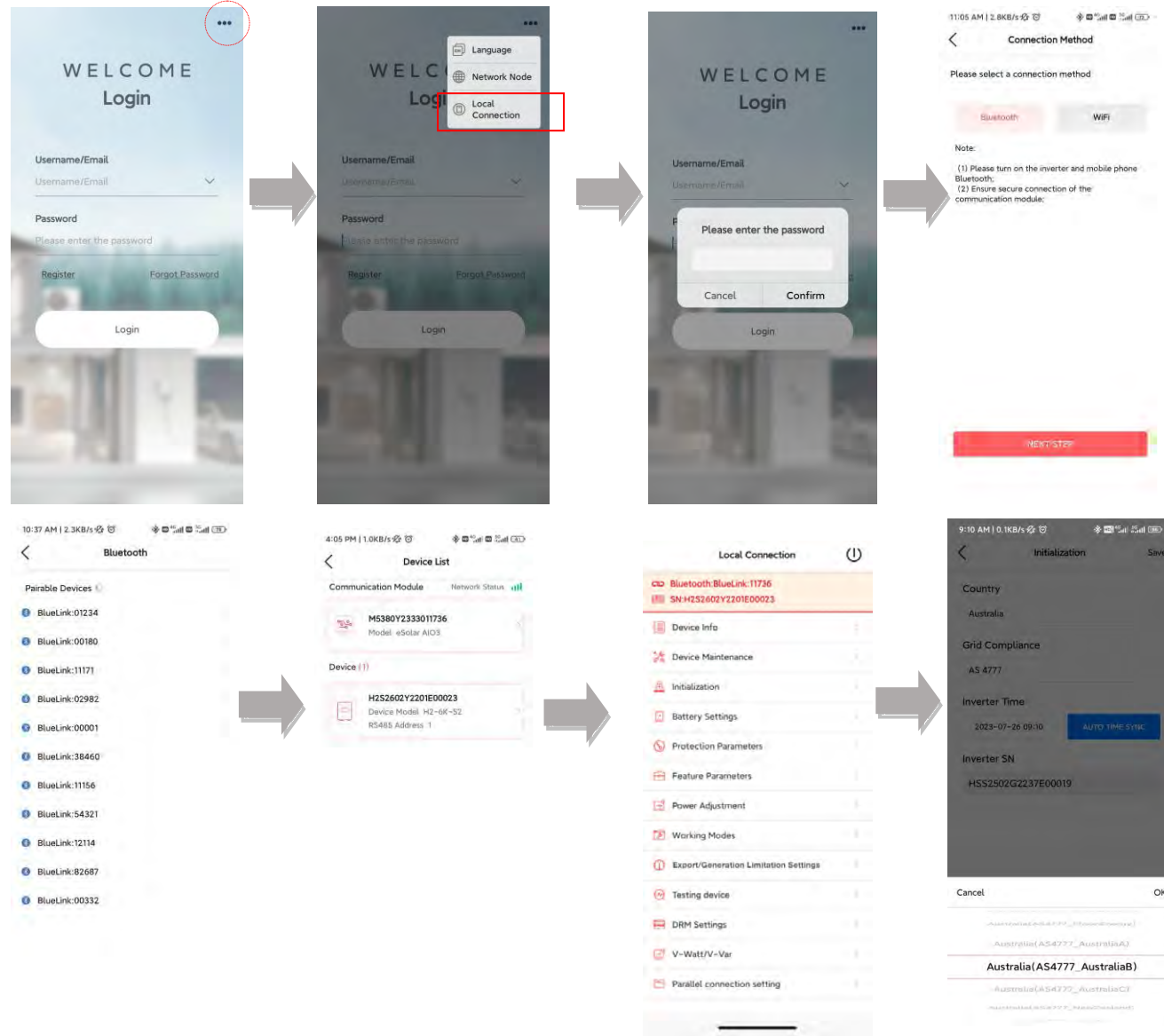

6.4.3 Inverter Setting Review

After commissioning, the device info including device basic info, running info and event info can be viewed. Country and grid code can be viewed from initial setting.

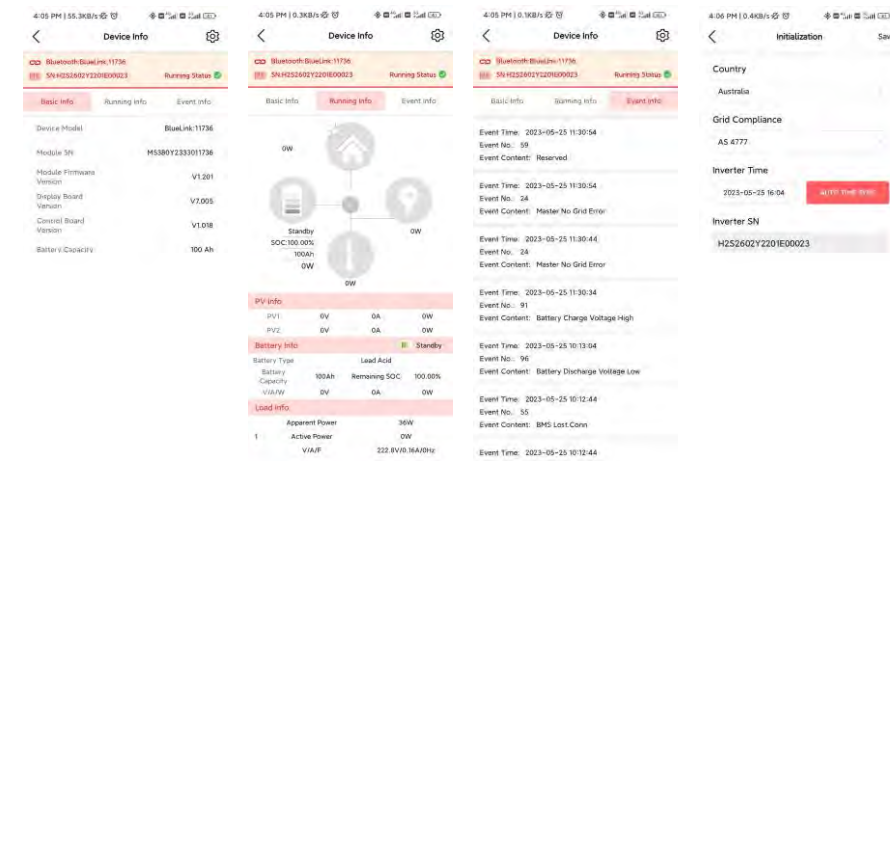

6.5 Working Modes

6.5.1 Selecting Working Modes Procedures

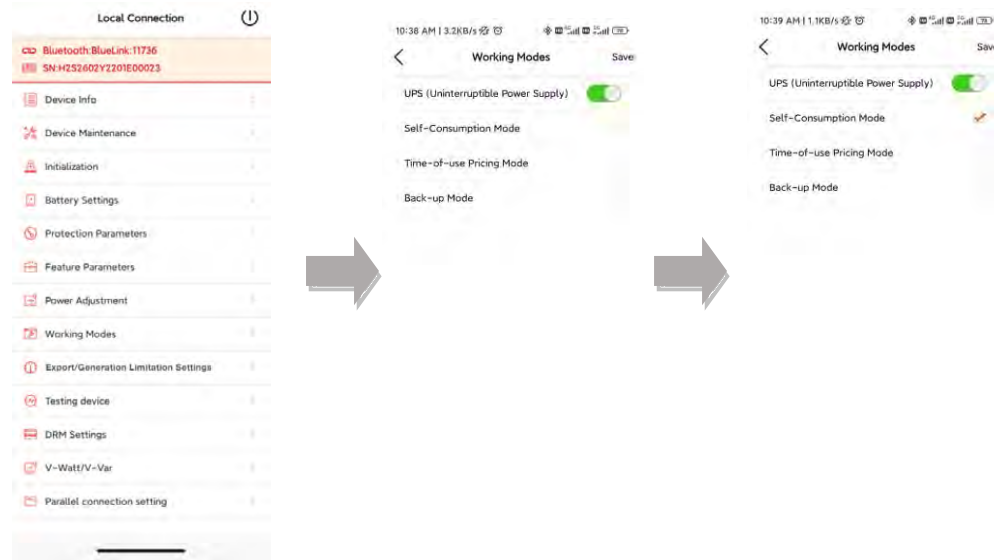

6.5.2 Working Modes Introduction

Self-consumption Mode: When the solar is sufficient, electricity generated by photovoltaic system will be supplied to load first, the surplus energy will be stored in battery, then the excess electricity will be exported to the grid. When the solar is insufficient, the battery will release electricity to supply load.

Back-up Mode: Reserved Backup SOC setting value can be adjusted, when battery SOC is less than reserved SOC value, battery can only be charged, until SOC reaches reserved value, the battery will be stopped charging; when SOC is larger than SOC setting value, battery will behave as Self-use mode.

Time-of-use Mode: Battery charging period and discharging period can be set, during charging period, battery can only be charged, while in discharging period, battery can only be discharged, the rest of the period, battery will behave as Self-use mode.

6.6 Export Limit Setting

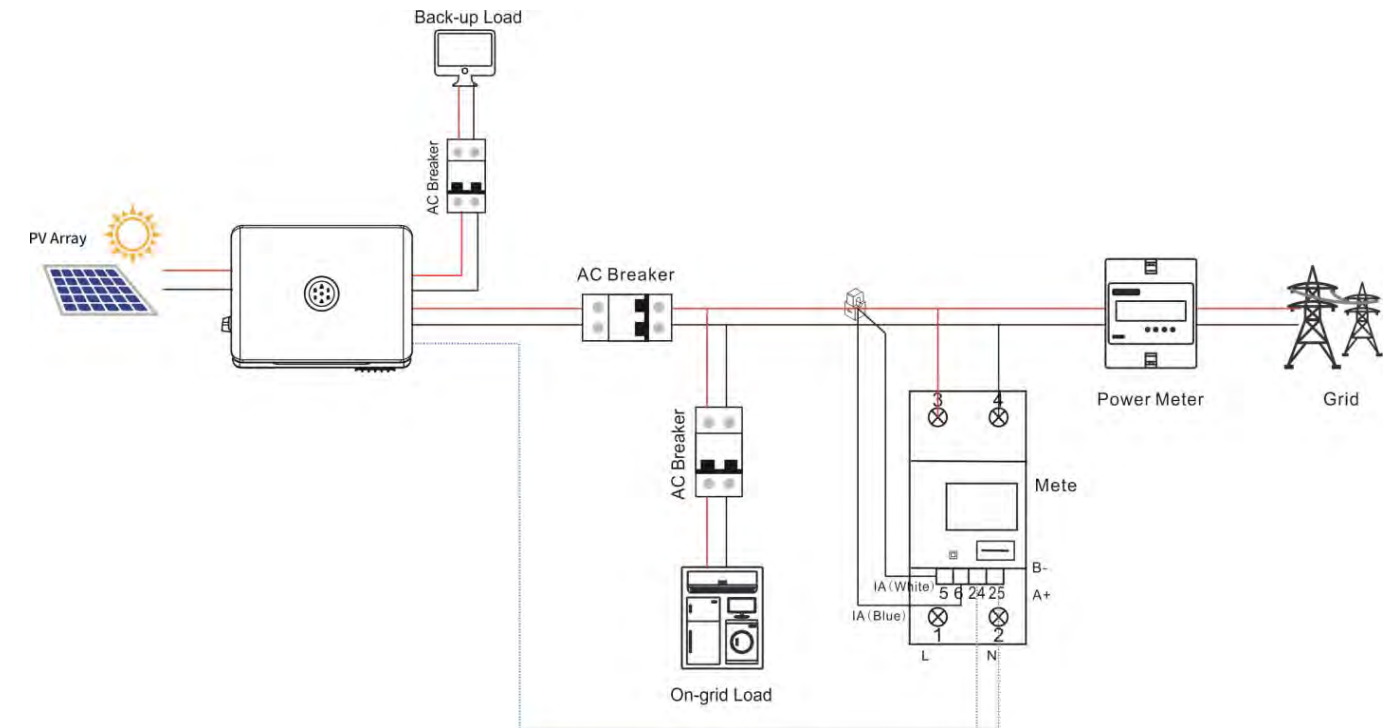

Note: If the RS485 cable length between inverter and meter is longer than 20m, please install the 120Ω resistor in port 24&25 of the meter.

6.6.1 APP Setting



There are two methods to control the export limit, the two methods are alternative to each other.

Method 1: Export limitation setting is to control the export electricity to the grid.

Method 2: Generation limit is to control the electricity generated by the inverter.

6.7 Self-test (For Italy)

Italian Standard CEI0-21 requires a self-test function for all inverter that connected to utility grid. During the self-testing time, inverter will check the reaction time for over frequency, under frequency, overvoltage and undervoltage. This self-test is to ensure the inverter is able to disconnect from grid when required. If the self-test fails, the inverter will not be able to feed into the grid.

The steps of running Self-test are as followed:

Step 1: Connect a communication module (Wi-Fi/ 4G/Ethernet) with inverter (connection procedure can refer to eSolar Module Quick Installation Manual)

Step 2: Select Italy for Country and choose your corresponding Grid Code from Initial Setting.

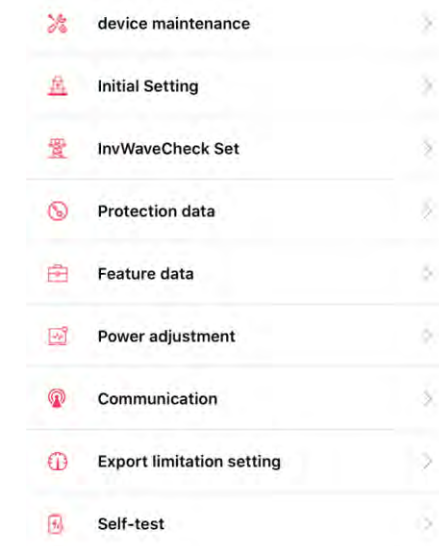

Step 3: You can choose self-test item required. Individual self-test time is approx. 5 minutes. All self-test time is approx. 40 minutes. After the self-test is completed, you can save the test report. If self-test is failed, please contact with SAJ or your inverter supplier.

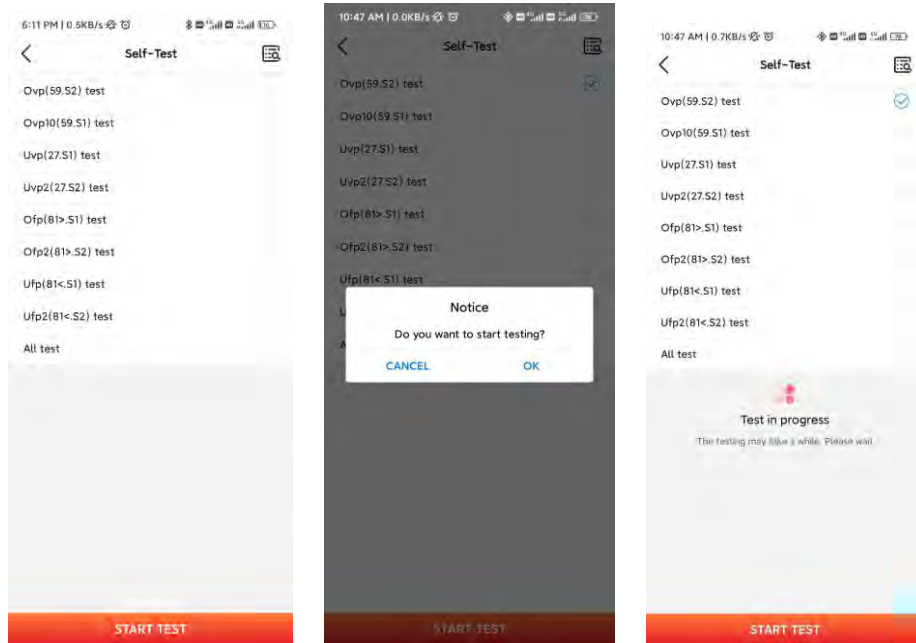

6.8 Setting Reactive Power Control (For Australia)

6.8.1 Setup Fixed Power Factor Mode & Fixed Reactive Power Mode

Fixed Power Factor Mode

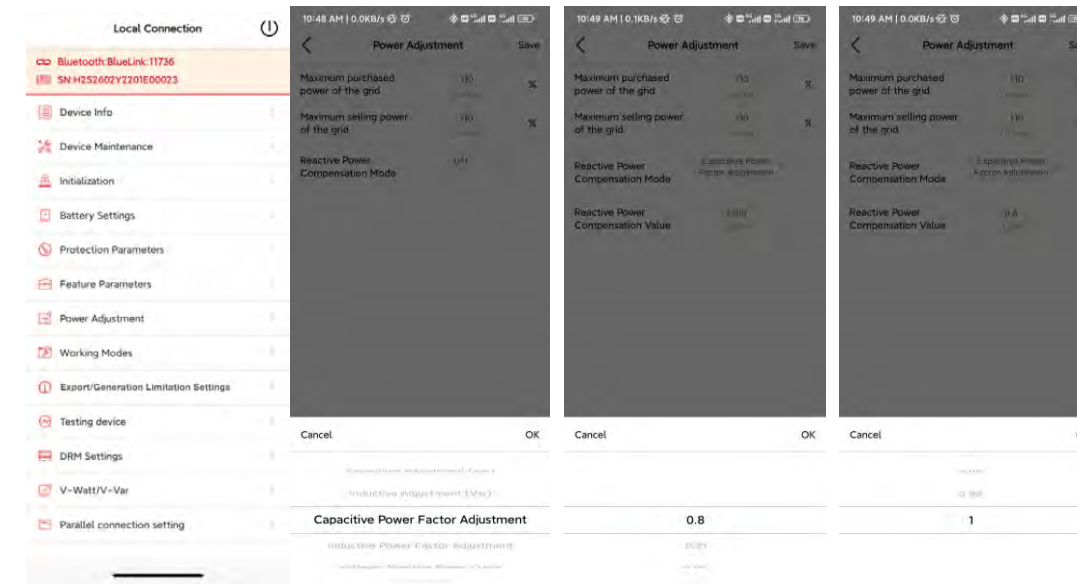

Step 1: Select Power Adjustment and enter password "201561".

Step 2: Select Capacitive Power Factor or Inductive Power Factor according to your local grid regulation. The power factor range is from 0.8 leading ~ 0.8 lagging.

Fixed Reactive Power Mode

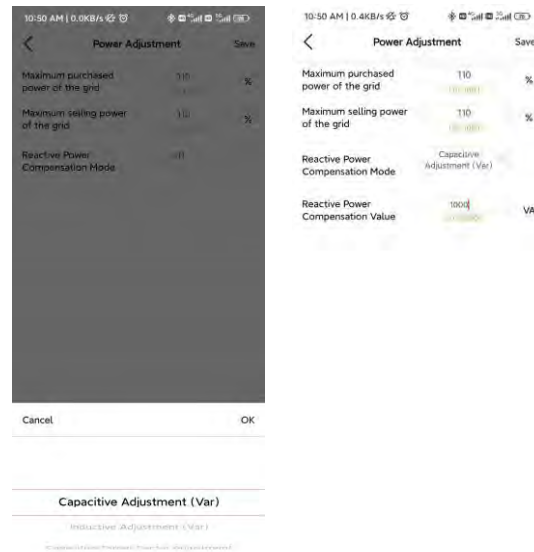

Step 1: Select Inductive Adjustment Var or Capacitive Var according to your local grid regulation. The power range is from $-60\%P_n \sim 60\%P_n$.

6.8.2 Setup V-Watt and Volt-Var Mode

This inverter complies with AS/NZS 4777.2: 2020 for power quality response modes. The inverter satisfies different regions of DNSPs' grid connection rules requirements for volt-watt and volt-var Settings. e.g.: AS4777 series setting as below Fig 6.2&6.3.

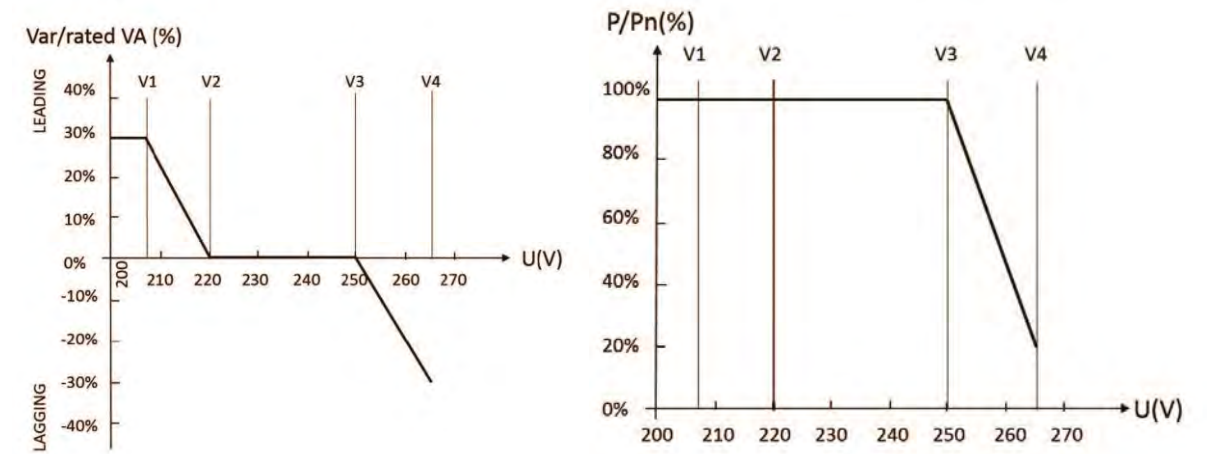

Figure 6.2

Curve for a Volt-Watt response mode (AS4777 Series)

Figure 6.3

Curve for a Volt-Var control mode (AS4777 Series)

Setting procedure:

1. AS4777 grid compliance has been set during production, please select corresponding grid compliance according to state regulation during installation. You can choose a state regulation compliance with your local grid via eSAJ Home.
2. Log in to eSAJ Home, click "Local Connection", for connection procedure please refer to chapter 5.3 for Nearby monitoring.
3. Click "V-Watt/V-Var" to enter DNSPs settings, choose a suitable state regulation from the drop down list.

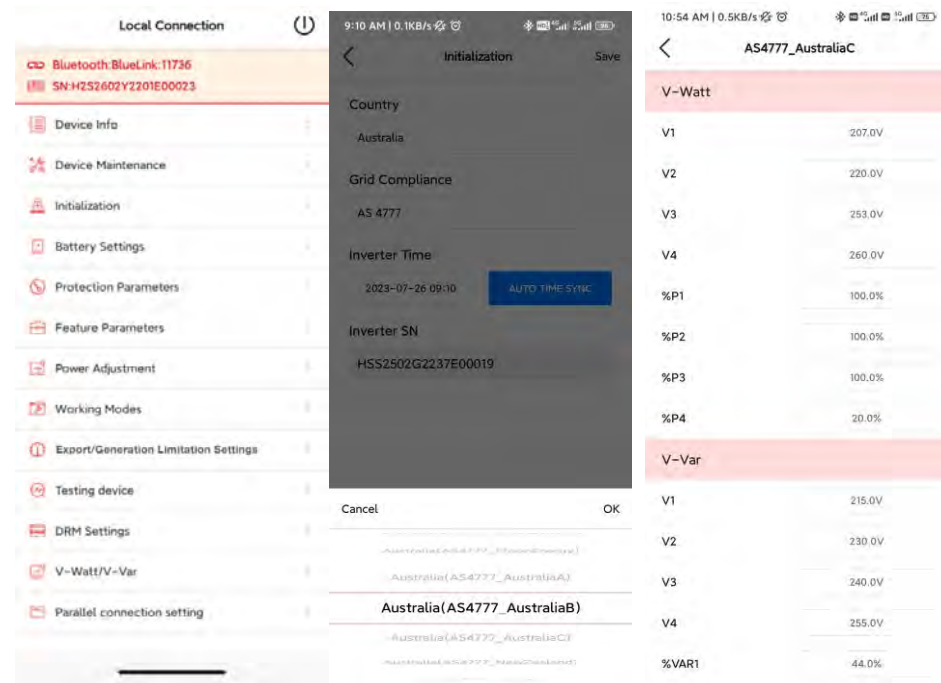
**Note:**

With regard to the Power rate limit mode, SAJ sets the product WGr_a to 16.67%P_n by default in the following cases according to the requirements of 3.3.5.2 as 4777.2: 2020.

1. Soft ramp up after connect.
2. Reconnect or soft ramp up/down following a response to frequency disturbance.

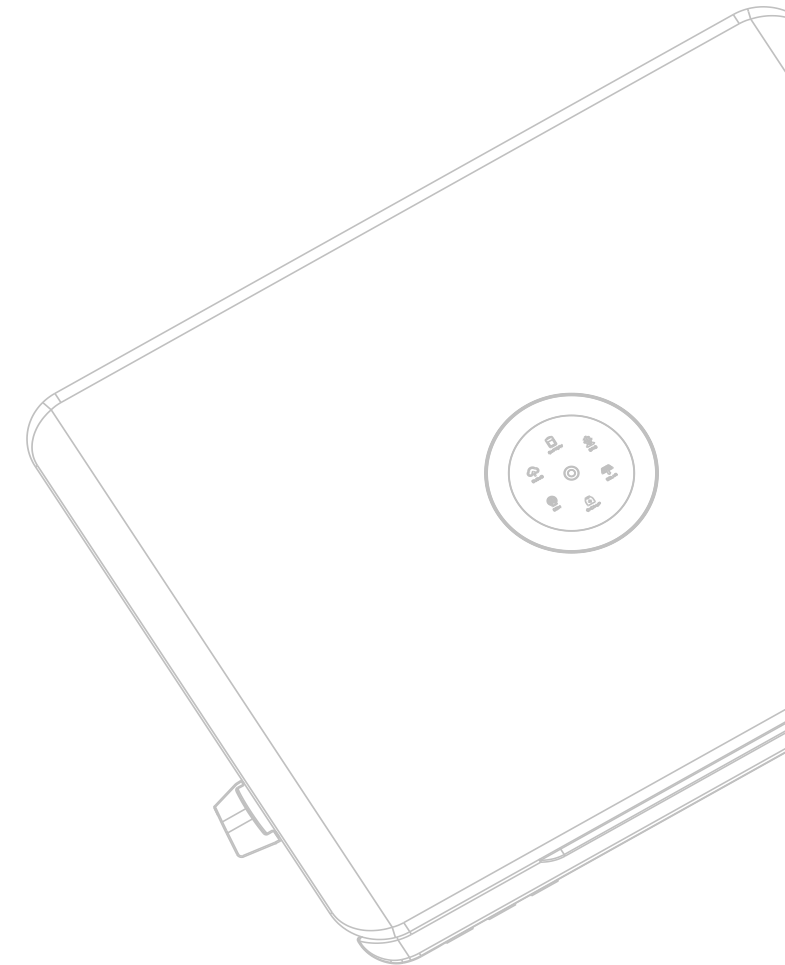

7.

TRANSPORTATION & DISPOSAL



7.1 Transportation

Take care of the product during transportation and storage, keep less than 4 cartons of inverter in one stack.

7.2 Recycling and Disposal



This device should not be disposed as residential waste. An inverter that has reached the end of its life and is not required to be returned to your dealer, it must be disposed carefully by an approved collection and recycling facility in your area.

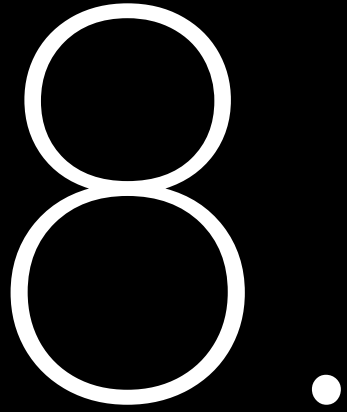

ROUTINE MAINTENANCE



Inverter Cleaning

Clean the enclosure lid and LED indicator of the inverter with moistened cloth with clear water only. Do not use any cleaning agents as it may damage the components.

Heat Sink Cleaning

Clean the heat sinks with dry cloth or air blower. Do not clean the heat sink with water or cleaning agents. Make sure there is enough space for ventilation of inverter.

Troubleshooting

Code	Fault Information
1	Master Relay Error
2	Master EEPROM Error
3	Master Temperature High Error
4	Master Temperature Low Error
5	Lost Communication M<->S
6	GFCI Device Error
7	DCI Device Error
8	Current Sensor Error
9	Master Phase1 Voltage High
10	Master Phase1 Voltage Low
11	Master Phase2 Voltage High
12	Master Phase2 Voltage Low
13	Master Phase3 Voltage High
14	Master Phase3 Voltage Low
15	Grid Voltage 10Min High
16	OffGrid Output Voltage Low
17	OffGrid Output Short Circuit
18	Master Grid Frequency High
19	Master Grid Frequency Low
21	Phase1 DCV High
22	Phase2 DCV High
23	Phase3 DCV High
24	Master No Grid Error
27	GFCI Error
28	Phase1 DCI Error
29	Phase2 DCI Error
30	Phase3 DCI Error
31	ISO Error
32	Bus Voltage Balance Error
33	Master Bus Voltage High
34	Master Bus Voltage Low
35	Master Grid Phase Lost
36	Master PV Voltage High

Code	Fault Information
37	Master Islanding Error
38	Master HW Bus Voltage High
39	Master HW PV Current High
40	Master Self-Test Failed
41	Master HW Inv Current High
42	Master AC SPD Error
43	Master DC SPD Error
44	Master Grid NE Voltage Error
45	Master Fan1 Error
46	Master Fan2 Error
47	Master Fan3 Error
48	Master Fan4 Error
49	Lost Communication between Master and Meter
50	Lost Communication between M<->S
51	Lost Communication between inverter and Grid Meter
52	HMI EEPROM Error
53	HMI RTC Error
54	BMS Device Error
55	BMS Lost.Conn
56	CT Device Err
57	AFCI Lost Err
58	Lost Com. H<->S Err
59	Lost Communication between inverter and PV Meter
61	Slave Phase1 Voltage High
62	Slave Phase1 Voltage Low
63	Slave Phase2 Voltage High
64	Slave Phase2 Voltage Low
65	Slave Phase3 Voltage High
66	Slave Phase3 Voltage Low
67	Slave Frequency High
68	Slave Frequency Low

TROUBLESHOOTING & WARRANTY



Code	Fault Information
73	Slave No Grid Error
74	Slave PV Input Mode Error
75	Slave HW PV Curr High
76	Slave PV Voltage High
77	Slave HW Bus Volt High
81	Lost Communication D<->C
83	Master Arc Device Error
84	Master PV Mode Error
85	Authority expires
86	DRM0 Error
87	Master Arc Error
88	Master SW PV Current High
89	Battery Voltage High
90	Battery Current High
91	Battery Charge Voltage High
92	Battery OverLoad
93	Battery SoftConnet TimeOut
94	Output OverLoad
95	Battery Open Circuit Error
96	Battery Discharge Voltage Low

Please contact your supplier for troubleshooting and remedy.

Warranty

Please go to SAJ website for warranty conditions and terms
<https://www.saj-electric.com/>